

# DRAGON CENTRIFUGAL PUMPS

Thermoplastic centrifugal pumps with mechanical seal

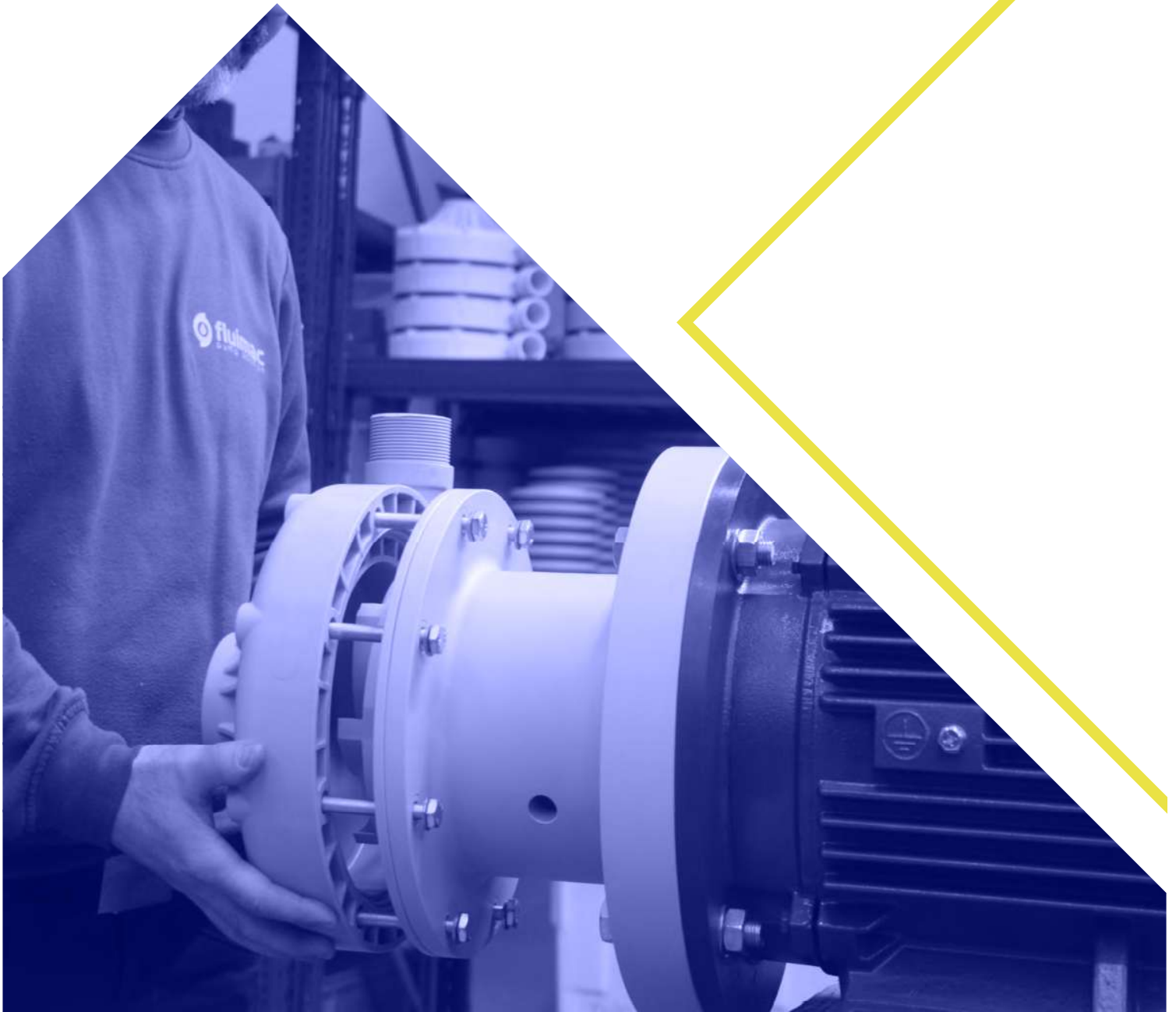

# DRAGON SERIES



DRAGON plastic horizontal centrifugal pumps are high performance pumps operated by a direct-drive electric motor for fast fluid transfer and drainage with flow-rates ranging from 6 to 40 m<sup>3</sup>/h. The special semi-opened impeller design allows continuous pumping even with dirty fluids with apparent viscosity up to 500cps. and small suspended solids.

DRAGON centrifugal pumps feature a solid pump casing and a lantern for connecting the electric motor and inspection of the mechanical seal. The semi-opened impeller is fitted to the pump shaft that is integral with the drive shaft of the electric motor. The shaft mechanical seal is housed at the rear of the impeller.

## MAIN FEATURES

- Casing and impeller in PP and PVDF
- O-ring in EPDM and VITON
- Single Mechanical Seal
- Max delivery head 25 mts
- Max flow - Rate: 40 m<sup>3</sup>/h
- Temperature: from -20 °C to + 95°C
- Max viscosity: 500 CPS
- Electric motors from 0,37 Kw up to 5,5kW
- Specific Gravity up to 1.9

## INSTALLATION



### POSITIVE SUCTION:

DRAGON centrifugal pumps should only be installed with the shaft positioned horizontally in a positive suction head arrangement. Suitable devices should be fitted to prevent dry running and the formation of a vortex and possible air suction. Running dry or with air bubbles can cause damage to the mechanical seal.

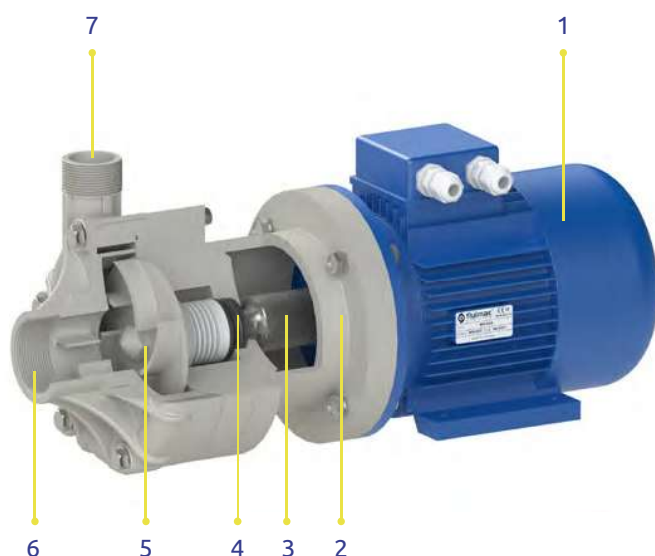

- 1 Electric motor
- 2 Inspection lantern
- 3 Shaft
- 4 Mechanical Seal
- 5 Impeller
- 6 Inlet
- 7 Outlet

# DRAGON SERIES



DRAGON mechanical seal is designed with externally 100% virgin PTFE bellows for extreme corrosion resistance applications. The entire seal assembly and component parts employ mechanical drive to prevent slippage on the shaft or sleeve. Seal assembly is outside mounted and internally pressurized.

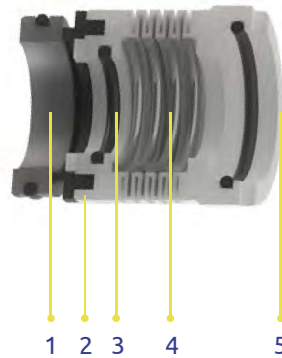

## MAIN FEATURES

- Special design
- Anti-rotation
- High chemical design
- SiC/C/FPM/SS304
- Able to handle dirty fluid

- 1** Static Seal in SILICON CARBIDE
- 2** Dynamic Seal in CARBON
- 3** Gasket in FPM
- 4** Spring in SS AISI 316
- 5** Bellows in PTFE

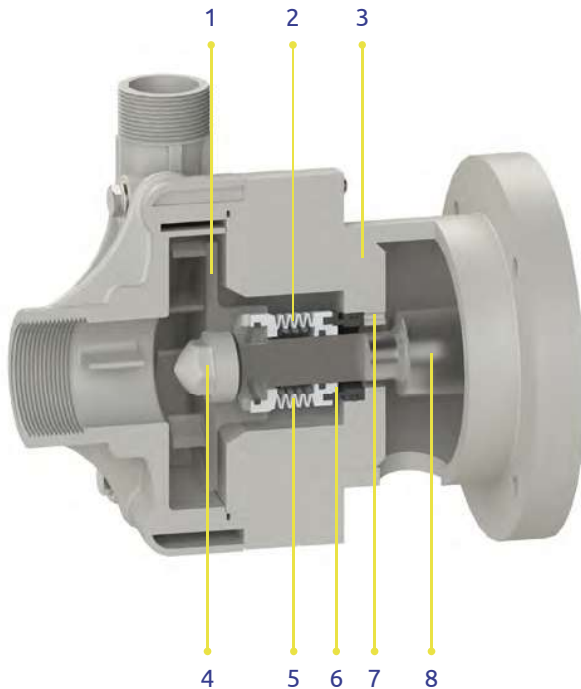

- 1** Semi-opened impeller
- 2** Bellows
- 3** Seal-holding flange
- 4** Fluid cap
- 5** Spring
- 6** Dynamic seal ring
- 7** Static seal ring
- 8** Shaft

# DRAGON SERIES

## DR 6

PP



PVDF



### TECHNICAL DATA

- Inlet connections 1" 1/2 F BSPP
- Outlet connections 1" M BSPP
- Max. Flow rate 9,2 m<sup>3</sup>/h
- Max. Delivery head 6,4 m
- Max Viscosity 100 CPS
- Temperature PP -5°C +65°C
- Temperature PVDF -20°C +95°C
- Impeller Semi-Opened

### PERFORMANCE

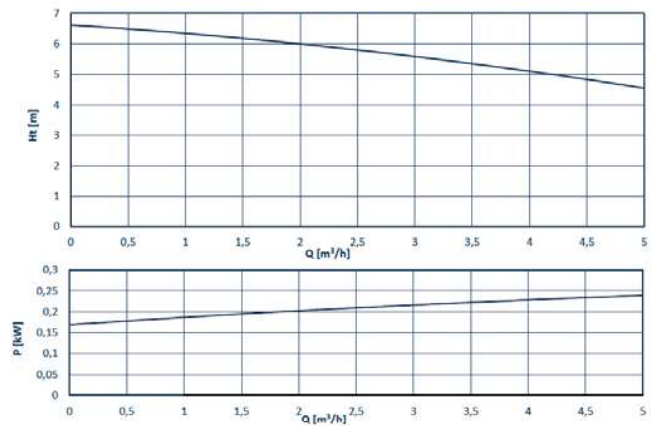

The curves and performance data refer to pumps with free discharge, water at 20°C, and a two poles, 50 Hz motor. Four poles curves are available on page 34. This data may vary depending on construction materials and hydraulic conditions.

### MOTOR AND DIMENSIONS

Size	IEC 71	IEC 71	IEC 80
kW	0,37	0,55	0,75
Weight kg*	5,6	6,1	9,1
A* mm	225	225	250
B* mm	183	183	212
C* mm	160	160	200
D* mm	71	71	80
E* mm	90	90	100
F* mm	112	112	125
LT* mm	204,5	204,5	204,5
LF* mm	137	137	137

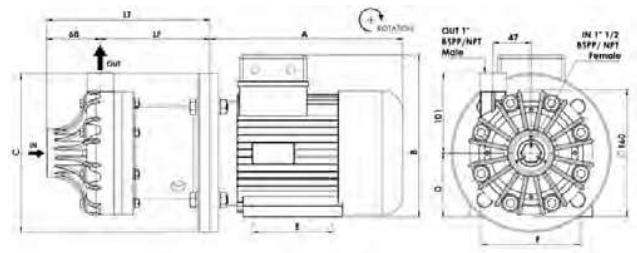

Standard motors: 2-pole, B3B5, 2900 rpm, 50 Hz, 230/400 V, IP55, IEC flange.

### COMPOSITION

MODEL	CASING	O-RING	MECHANICAL SEAL	CONNECTIONS	SIZE	MOTOR VERSION
DR006	P = PP	D = EPDM	T1 = SIC + C	1 = BSPP STD	71	IE = IEC FLANGE
	K = PVDF	V = VITON		2 = FLANGED	80	- = NO MOTOR
				5 = NPT	90	

# DRAGON SERIES

## DR 10

PP



PVDF



### TECHNICAL DATA

- Inlet connections 1" 1/2 F BSPP
- Outlet connections 1" M BSPP
- Max. Flow rate 11,2 m<sup>3</sup>/h
- Max. Delivery head 9 m
- Max Viscosity 150 CPS
- Temperature PP -5°C +65°C
- Temperature PVDF -20°C +95°C
- Impeller Semi-Opened

### PERFORMANCE

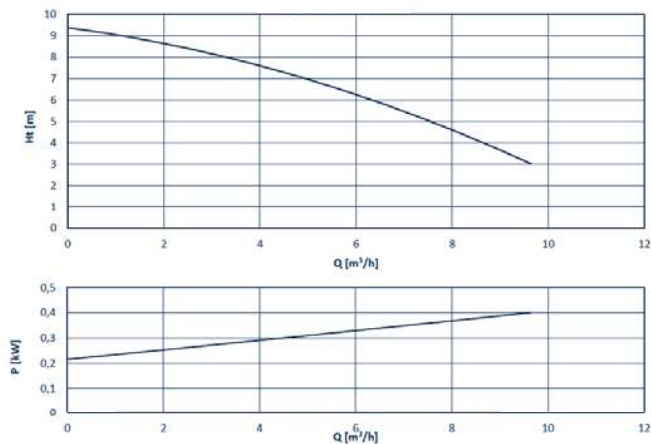

The curves and performance data refer to pumps with free discharge, water at 20°C, and a two poles, 50 Hz motor. Four poles curves are available on page 34. This data may vary depending on construction materials and hydraulic conditions.

### MOTOR AND DIMENSIONS

Size	IEC 71	IEC 80	IEC 80	IEC 90S
kW	0,55	0,75	1,1	1,5
Weight kg*	6,1	9,1	10,2	12
A* mm	250	250	250	260
B* mm	183	212	212	230
C* mm	160	200	200	200
D* mm	71	80	80	90
E* mm	90	100	100	100
F* mm	112	125	125	140
LT* mm	204,5	204,5	204,5	216,5
LF* mm	137	137	137	149

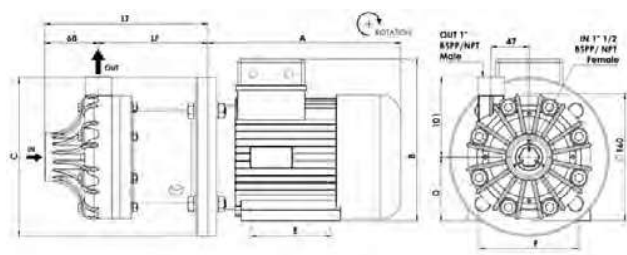

Standard motors: 2-pole, B3B5, 2900 rpm, 50 Hz, 230/400 V, IP55, IEC flange.

### COMPOSITION

MODEL	CASING	O-RING	MECHANICAL SEAL	CONNECTIONS	SIZE	MOTOR VERSION
DR010	P = PP	D = EPDM	T1 = SIC + C	1 = BSPP STD	71	IE = IEC FLANGE
	K = PVDF	V = VITON		2 = FLANGED	80	- = NO MOTOR
				5 = NPT	90	

# DRAGON SERIES

## DR 15



### TECHNICAL DATA

- Inlet connections 1" 1/2 F BSPP
- Outlet connections 1" M BSPP
- Max. Flow rate 13 m<sup>3</sup>/h
- Max. Delivery head 11 m
- Max Viscosity 200 CPS
- Temperature PP -5°C +65°C
- Temperature PVDF -20°C +95°C
- Impeller Semi-Opened

### PERFORMANCE

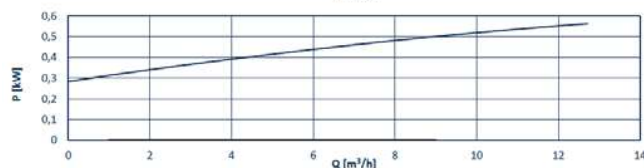
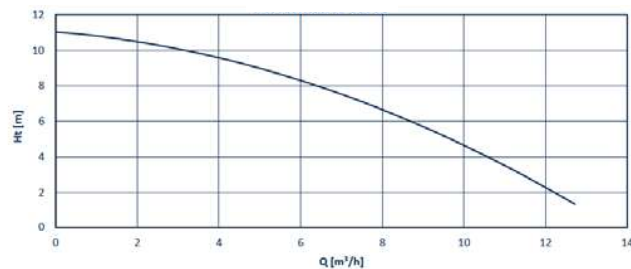

The curves and performance data refer to pumps with free discharge, water at 20°C, and a two poles, 50 Hz motor. Four poles curves are available on page 34. This data may vary depending on construction materials and hydraulic conditions.

### MOTOR AND DIMENSIONS

Size	IEC 80	IEC 80	IEC 90S
kW	0,75	1,1	1,5
Weight kg*	9,1	10,2	12
A* mm	250	250	260
B* mm	212	212	230
C* mm	200	200	200
D* mm	80	80	90
E* mm	100	100	100
F* mm	125	125	140
LT* mm	204,5	204,5	216,5
LF* mm	137	137	149

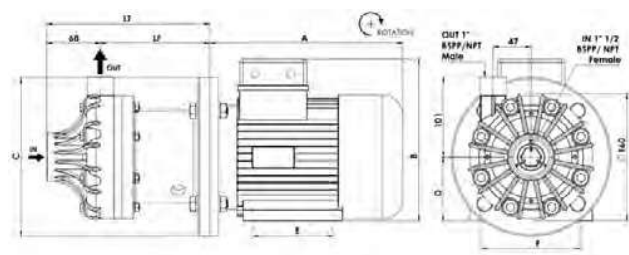

Standard motors: 2-pole, B3B5, 2900 rpm, 50 Hz, 230/400 V, IP55, IEC flange.

### COMPOSITION

MODEL	CASING	O-RING	MECHANICAL SEAL	CONNECTIONS	SIZE	MOTOR VERSION
DR015	P = PP	D = EPDM	T1 = SIC + C	1 = BSPP STD	71	IE = IEC FLANGE
	K = PVDF	V = VITON		2 = FLANGED	80	- = NO MOTOR
				5 = NPT	90	

# DRAGON SERIES

## DR 20



### TECHNICAL DATA

- Inlet connections 2" F BSPP
- Outlet connections 1" 1/2 M BSPP
- Max. Flow rate 28,5 m<sup>3</sup>/h
- Max. Delivery head 13 m
- Max Viscosity 300 CPS
- Temperature PP -5°C +65°C
- Temperature PVDF -20°C +95°C
- Impeller Semi-Opened

### PERFORMANCE

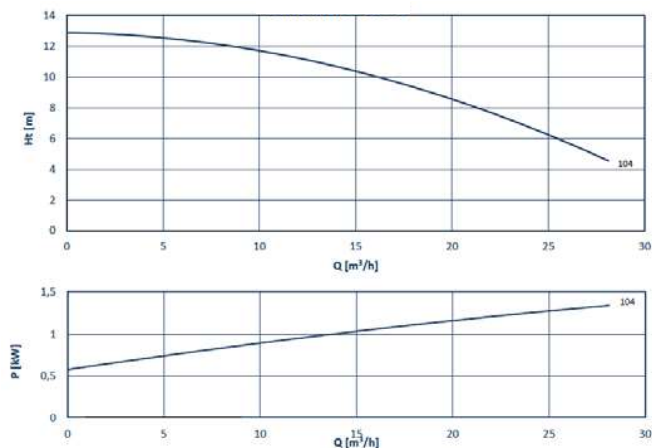

The curves and performance data refer to pumps with free discharge, water at 20°C, and a two poles, 50 Hz motor. Four poles curves are available on page 34. This data may vary depending on construction materials and hydraulic conditions.

### MOTOR AND DIMENSIONS

Size	IEC 90S	IEC 90L	IEC 100L	IEC 112	IEC 132S
kW	1,5	2,2	3	4	5,5
Weight kg*	12	15	22,3	26,7	38,5
A* mm	260	285	326	335	356
B* mm	230	230	247	286	319
C* mm	200	200	250	250	300
D* mm	90	90	100	112	132
E* mm	100	125	140	140	140
F* mm	140	140	160	190	216
LT* mm	270,5	270,5	270,5	270,5	289,5
LF* mm	179,5	179,5	179,5	179,5	198,5

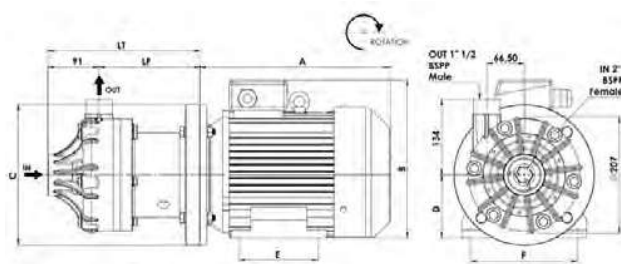

Standard motors: 2-pole, B3B5, 2900 rpm, 50 Hz, 230/400 V, IP55, IEC flange.

### COMPOSITION

MODEL	CASING	O-RING	MECHANICAL SEAL	CONNECTIONS	SIZE	MOTOR VERSION
DR020	P = PP	D = EPDM	T1 = SIC + C	1 = BSPP STD	80	IE = IEC FLANGE
	K = PVDF	V = VITON		2 = FLANGED	90	- = NO MOTOR
					100	
					112	
					132	

# DRAGON SERIES

## DR 25



### TECHNICAL DATA

- Inlet connections 2 F BSPP
- Outlet connections 1" 1/2 M BSPP
- Max. Flow rate 31 m<sup>3</sup>/h
- Max. Delivery head 17 m
- Max Viscosity 400 CPS
- Temperature PP -5°C +65°C
- Temperature PVDF -20°C +95°C
- Impeller Semi-Opened

### PERFORMANCE

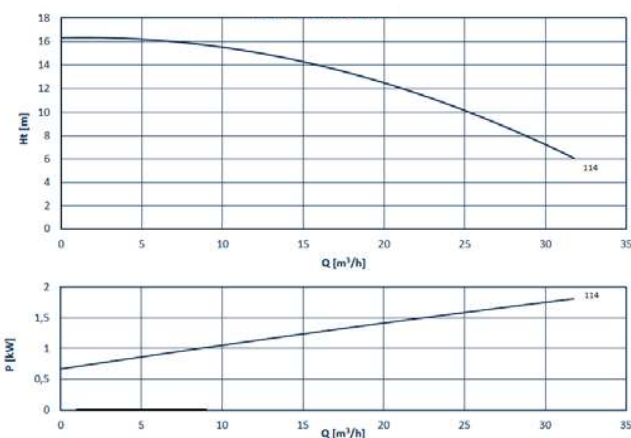

The curves and performance data refer to pumps with free discharge, water at 20°C, and a two poles, 50 Hz motor. Four poles curves are available on page 34. This data may vary depending on construction materials and hydraulic conditions.

### MOTOR AND DIMENSIONS

Size	IEC 90S	IEC 90L	IEC 100L	IEC 112	IEC 132S
kW	1,5	2,2	3	4	5,5
Weight kg*	12	15	22,3	26,7	38,5
A* mm	260	285	326	335	356
B* mm	230	230	247	286	319
C* mm	200	200	250	250	300
D* mm	90	90	100	112	132
E* mm	100	125	140	140	140
F* mm	140	140	160	190	216
LT* mm	270,5	270,5	270,5	270,5	289,5
LF* mm	179,5	179,5	179,5	179,5	198,5

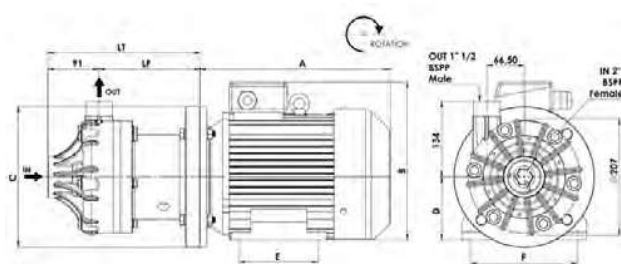

Standard motors: 2-pole, B3B5, 2900 rpm, 50 Hz, 230/400 V, IP55, IEC flange.

### COMPOSITION

MODEL	CASING	O-RING	MECHANICAL SEAL	CONNECTIONS	SIZE	MOTOR VERSION
DR025	P = PP	D = EPDM	T1 = SIC + C	1 = BSPP STD	80	IE = IEC FLANGE
	K = PVDF	V = VITON		2 = FLANGED	90	- = NO MOTOR
					100	
					112	
					132	

# DRAGON SERIES

## DR 30



### TECHNICAL DATA

- Inlet connections 2" F BSPP
- Outlet connections 1" 1/2 M BSPP
- Max. Flow rate 34,5 m<sup>3</sup>/h
- Max. Delivery head 21 m
- Max Viscosity 500 CPS
- Temperature PP -5°C +65°C
- Temperature PVDF -20°C +95°C
- Impeller Semi-Opened

### PERFORMANCE

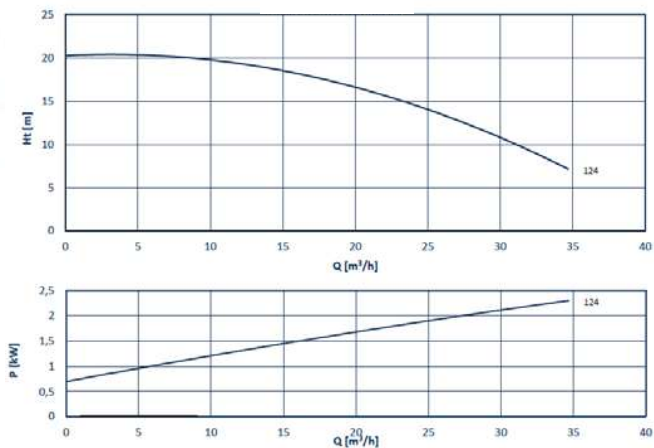

The curves and performance data refer to pumps with free discharge, water at 20°C, and a two poles, 50 Hz motor. Four poles curves are available on page 34. This data may vary depending on construction materials and hydraulic conditions.

### MOTOR AND DIMENSIONS

	Size	IEC 90L	IEC 100L	IEC 112	IEC 132S
	kW	2,2	3	4	5,5
Weight kg*		15	22,3	26,7	38,5
A* mm		285	326	335	356
B* mm		230	247	286	319
C* mm		200	250	250	300
D* mm		90	100	112	132
E* mm		125	140	140	140
F* mm		140	160	190	216
LT* mm		270,5	270,5	270,5	289,5
LF* mm		179,5	179,5	179,5	198,5

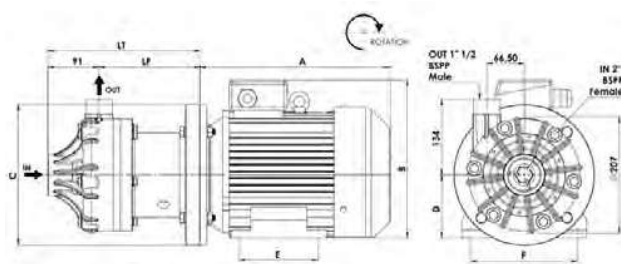

Standard motors: 2-pole, B3B5, 2900 rpm, 50 Hz, 230/400 V, IP55, IEC flange.

### COMPOSITION

MODEL	CASING	O-RING	MECHANICAL SEAL	CONNECTIONS	SIZE	MOTOR VERSION
DR030	P = PP	D = EPDM	T1 = SIC + C	1 = BSPP STD	80	IE = IEC FLANGE
	K = PVDF	V = VITON		2 = FLANGED	90	- = NO MOTOR
					100	
					112	
					132	

# DRAGON SERIES

## DR 40



### TECHNICAL DATA

- Inlet connections 2" F BSPP
- Outlet connections 1" 1/2 M BSPP
- Max. Flow rate 38 m<sup>3</sup>/h
- Max. Delivery head 21 m
- Max Viscosity 500 CPS
- Temperature PP -5°C +65°C
- Temperature PVDF -20°C +95°C
- Impeller Semi-Opened

### PERFORMANCE

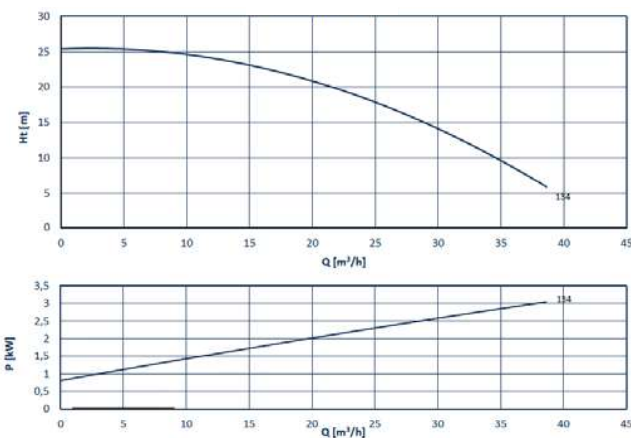

The curves and performance data refer to pumps with free discharge, water at 20°C, and a two poles, 50 Hz motor. Four poles curves are available on page 34. This data may vary depending on construction materials and hydraulic conditions.

### MOTOR AND DIMENSIONS

	Size	IEC 90L	IEC 100L	IEC 112	IEC 132S	IEC 132S
	kW	2,2	3	4	5,5	7,5
Weight kg*		15	22,3	26,7	38,5	42,2
A* mm		285	326	335	356	356
B* mm		230	247	286	319	319
C* mm		200	250	250	300	300
D* mm		90	100	112	132	132
E* mm		125	140	140	140	140
F* mm		140	160	190	216	216
LT* mm		270,5	270,5	270,5	289,5	326,5
LF* mm		179,5	179,5	179,5	198,5	234

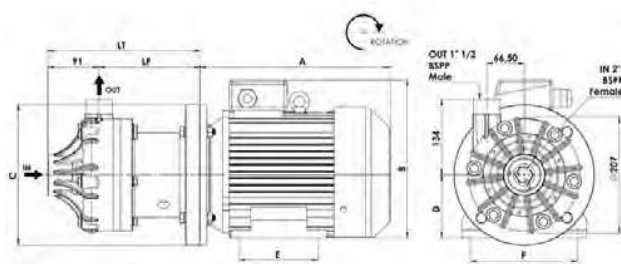

Standard motors: 2-pole, B3B5, 2900 rpm, 50 Hz, 230/400 V, IP55, IEC flange.

### COMPOSITION

MODEL	CASING	O-RING	MECHANICAL SEAL	CONNECTIONS	SIZE	MOTOR VERSION
DR040	P = PP	D = EPDM	T1 = SIC + C	1 = BSPP STD	80	IE = IEC FLANGE
	K = PVDF	V = VITON		2 = FLANGED	90	- = NO MOTOR
					100	
					112	
					132	

# DRAGON SERIES

## DR 45

PP



PVDF



### TECHNICAL DATA

- Inlet connections 2" 1/2 F BSPP
- Outlet connections 2" M BSPP
- Max. Flow rate 60 m<sup>3</sup>/h
- Max. Delivery head 26 m
- Max Viscosity 500 CPS
- Temperature PP -5°C +65°C
- Temperature PVDF -20°C +95°C
- Impeller Semi-Opened

### PERFORMANCE

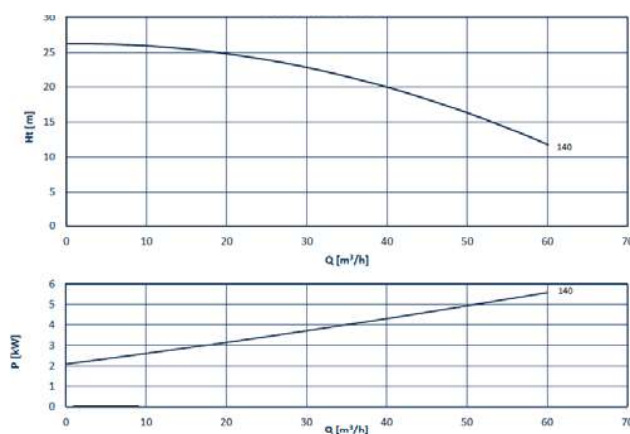

The curves and performance data refer to pumps with free discharge, water at 20°C, and a two poles, 50 Hz motor. Four poles curves are available on page 34. This data may vary depending on construction materials and hydraulic conditions.

### MOTOR AND DIMENSIONS

Size	IEC 112	IEC 132S	IEC 132S	IEC 160M
kW	4	5,5	7,5	11
Weight kg*	26,7	38,5	42,2	101
A* mm	335	356	356	500
B* mm	286	319	319	425
C* mm	250	300	300	350
D* mm	112	132	132	160
E* mm	140	140	140	210
F* mm	190	216	216	254
LT* mm	270,5	326,5	326,5	326,5
LF* mm	179,5	234	234	234

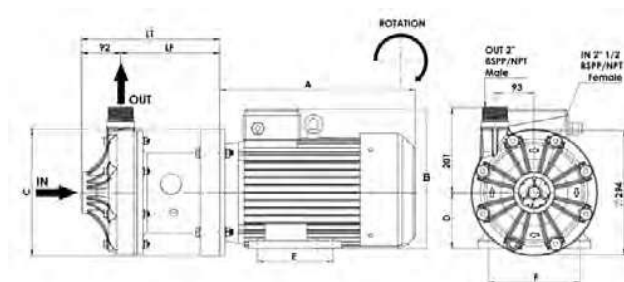

Standard motors: 2-pole, B3B5, 2900 rpm, 50 Hz, 230/400 V, IP55, IEC flange.

### COMPOSITION

MODEL	CASING	O-RING	MECHANICAL SEAL	CONNECTIONS	SIZE	MOTOR VERSION
DR045	P = PP	D = EPDM	T1 = SIC + C	1 = BSPP STD	100	IE = IEC FLANGE
	K = PVDF	V = VITON		2 = FLANGED	112	- = NO MOTOR
				5 = NPT	132	
					160	

# DRAGON SERIES

## DR 50

PP



PVDF



### TECHNICAL DATA

- Inlet connections 2" 1/2 F BSPP
- Outlet connections 2" M BSPP
- Max. Flow rate **64 m<sup>3</sup>/h**
- Max. Delivery head **30,5 m**
- Max Viscosity **600 CPS**
- Temperature PP **-5°C +65°C**
- Temperature PVDF **-20°C +95°C**
- Impeller **Semi-Opened**

### PERFORMANCE

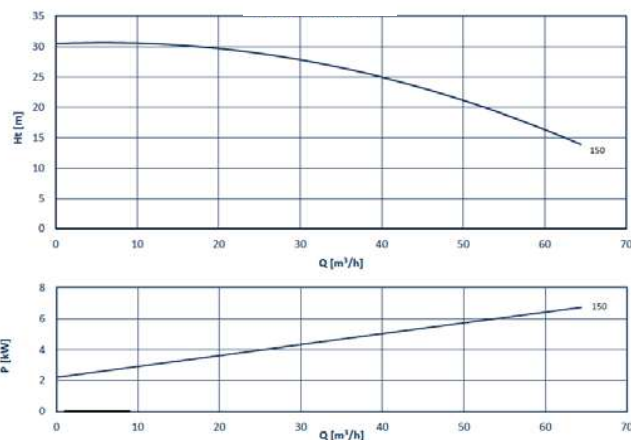

The curves and performance data refer to pumps with free discharge, water at 20°C, and a two poles, 50 Hz motor. Four poles curves are available on page 34. This data may vary depending on construction materials and hydraulic conditions.

### MOTOR AND DIMENSIONS

Size	IEC 132S	IEC 132S	IEC 160M	IEC 160M
kW	5,5	7,5	11	15
Weight kg*	38,5	42,2	101	111
A* mm	356	356	500	500
B* mm	319	319	425	425
C* mm	300	300	350	350
D* mm	132	132	160	160
E* mm	140	140	210	210
F* mm	216	216	254	254
LT* mm	326,5	326,5	326,5	326,5
LF* mm	234	234	234	234

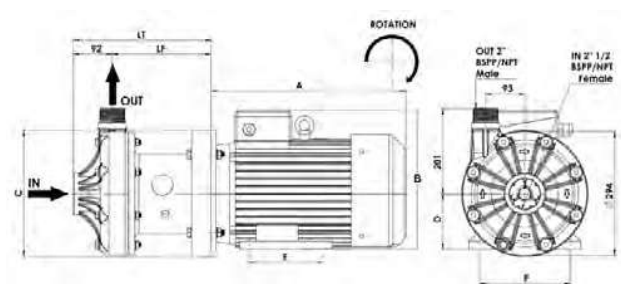

Standard motors: 2-pole, B3B5, 2900 rpm, 50 Hz, 230/400 V, IP55, IEC flange.

### COMPOSITION

MODEL	CASING	O-RING	MECHANICAL SEAL	CONNECTIONS	SIZE	MOTOR VERSION
DR050	P = PP	D = EPDM	T1 = SIC + C	1 = BSPP STD	100	IE = IEC FLANGE
	K = PVDF	V = VITON		2 = FLANGED	112	- = NO MOTOR
				5 = NPT	132	
					160	

# DRAGON SERIES

## DR 60

PP



PVDF



### TECHNICAL DATA

- Inlet connections 2" 1/2 F BSPP
- Outlet connections 2" M BSPP
- Max. Flow rate 68,5 m<sup>3</sup>/h
- Max. Delivery head 35 m
- Max Viscosity 700 CPS
- Temperature PP -5°C +65°C
- Temperature PVDF -20°C +95°C
- Impeller Semi-Opened

### PERFORMANCE

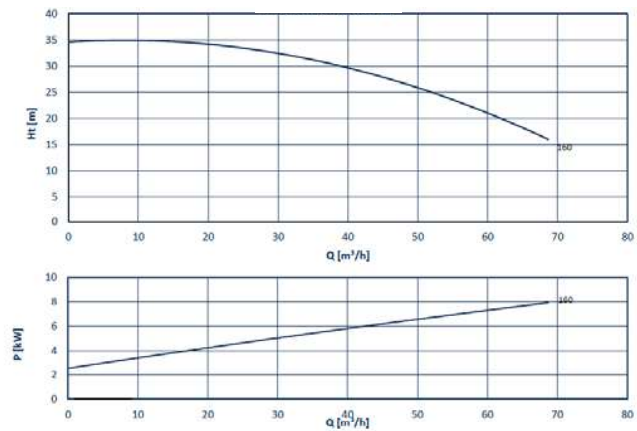

The curves and performance data refer to pumps with free discharge, water at 20°C, and a two poles, 50 Hz motor. Four poles curves are available on page 34. This data may vary depending on construction materials and hydraulic conditions.

### MOTOR AND DIMENSIONS

Size	IEC 132S	IEC 132S	IEC 160M	IEC 160M	IEC 160L
kW	5,5	7,5	11	15	18,5
Weight kg*	38,5	42,2	101	111	126
A* mm	356	356	500	500	545
B* mm	319	319	425	425	425
C* mm	300	300	350	350	350
D* mm	132	132	160	160	160
E* mm	140	140	210	210	254
F* mm	216	216	254	254	254
LT* mm	326,5	326,5	326,5	326,5	326,5
LF* mm	234	234	234	234	234

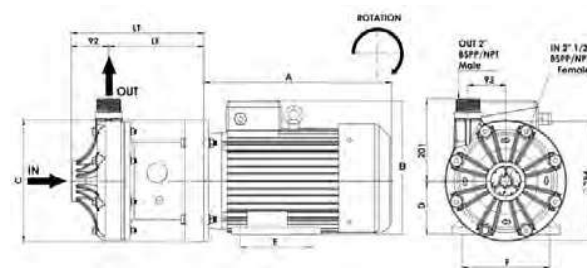

Standard motors: 2-pole, B3B5, 2900 rpm, 50 Hz, 230/400 V, IP55, IEC flange.

### COMPOSITION

MODEL	CASING	O-RING	MECHANICAL SEAL	CONNECTIONS	SIZE	MOTOR VERSION
DR060	P = PP	D = EPDM	T1 = SIC + C	1 = BSPP STD	100	IE = IEC FLANGE
	K = PVDF	V = VITON		2 = FLANGED	112	- = NO MOTOR
				5 = NPT	132	
					160	

# DRAGON SERIES

## DR 70



### TECHNICAL DATA

- Inlet connections 2" 1/2 F BSPP
- Outlet connections 2" M BSPP
- Max. Flow rate 73 m<sup>3</sup>/h
- Max. Delivery head 40 m
- Max Viscosity 800 CPS
- Temperature PP -5°C +65°C
- Temperature PVDF -20°C +95°C
- Impeller Semi-Opened

### PERFORMANCE

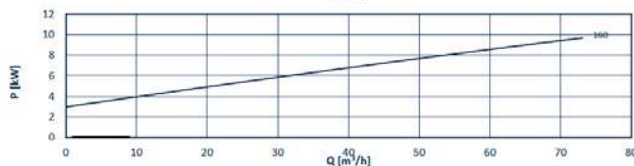
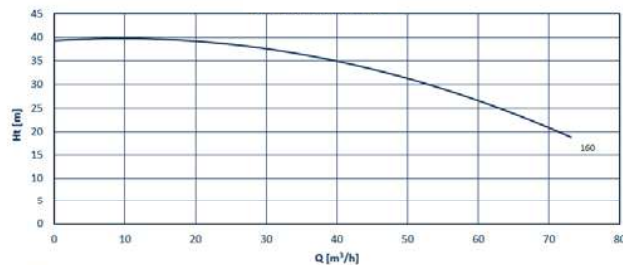

The curves and performance data refer to pumps with free discharge, water at 20°C, and a two poles, 50 Hz motor. Four poles curves are available on page 34. This data may vary depending on construction materials and hydraulic conditions.

### MOTOR AND DIMENSIONS

Size	IEC 132S	IEC 160M	IEC 160M	IEC 160L
kW	7,5	11	15	18,5
Weight kg*	42,2	101	111	126
A* mm	356	500	500	545
B* mm	319	425	425	425
C* mm	300	350	350	350
D* mm	132	160	160	160
E* mm	140	210	210	254
F* mm	216	254	254	254
LT* mm	326,5	326,5	326,5	326,5
LF* mm	234	234	234	234

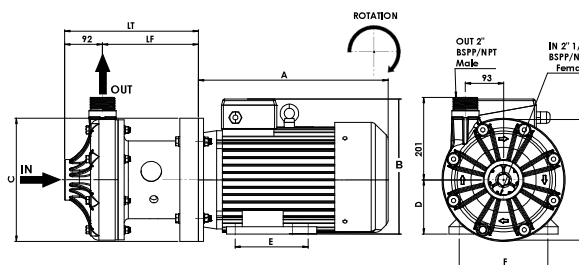

Standard motors: 2-pole, B3B5, 2900 rpm, 50 Hz, 230/400 V, IP55, IEC flange.

### COMPOSITION

MODEL	CASING	O-RING	MECHANICAL SEAL	CONNECTIONS	SIZE	MOTOR VERSION
DR070	P = PP	D = EPDM	T1 = SIC + C	1 = BSPP STD	100	IE = IEC FLANGE
	K = PVDF	V = VITON		2 = FLANGED	112	- = NO MOTOR
				5 = NPT	132	
					160	

# DRAGON SERIES

## DR 80

PP



PVDF



### TECHNICAL DATA

- Inlet connections 2" 1/2 F BSPP
- Outlet connections 2" M BSPP
- Max. Flow rate 78 m<sup>3</sup>/h
- Max. Delivery head 55 m
- Max Viscosity 800 CPS
- Temperature PP -5°C +65°C
- Temperature PVDF -20°C +95°C
- Impeller Semi-Opened

### PERFORMANCE

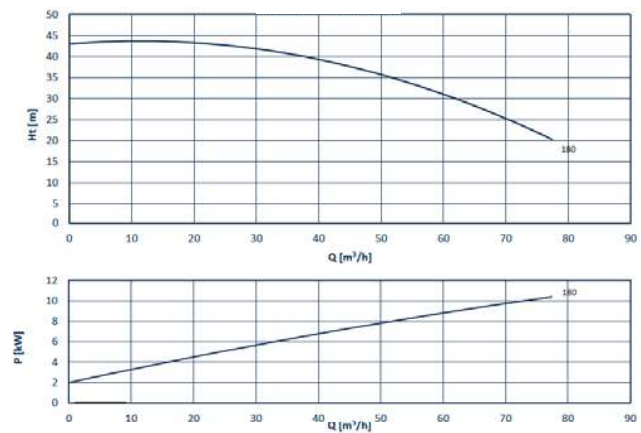

The curves and performance data refer to pumps with free discharge, water at 20°C, and a two poles, 50 Hz motor. Four poles curves are available on page 34. This data may vary depending on construction materials and hydraulic conditions.

### MOTOR AND DIMENSIONS

Size	IEC 132S	IEC 160M	IEC 160M	IEC 160L
kW	7,5	11	15	18,5
Weight kg*	42,2	101	111	126
A* mm	356	500	500	545
B* mm	319	425	425	425
C* mm	300	350	350	350
D* mm	132	160	160	160
E* mm	140	210	210	254
F* mm	216	254	254	254
LT* mm	326,5	326,5	326,5	326,5
LF* mm	234	234	234	234

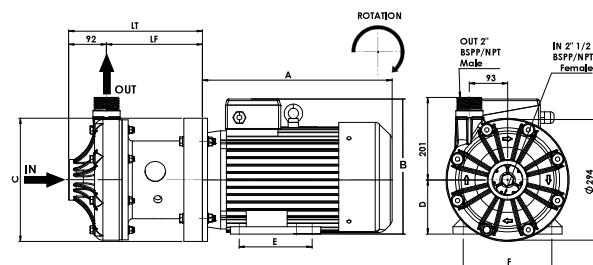

Standard motors: 2-pole, B3B5, 2900 rpm, 50 Hz, 230/400 V, IP55, IEC flange.

### COMPOSITION

MODEL	CASING	O-RING	MECHANICAL SEAL	CONNECTIONS	SIZE	MOTOR VERSION
DR080	P = PP	D = EPDM	T1 = SIC + C	1 = BSPP STD	100	IE = IEC FLANGE
	K = PVDF	V = VITON		2 = FLANGED	112	- = NO MOTOR
				5 = NPT	132	
					160	

# DRAGON SERIES 4 POLES CURVES

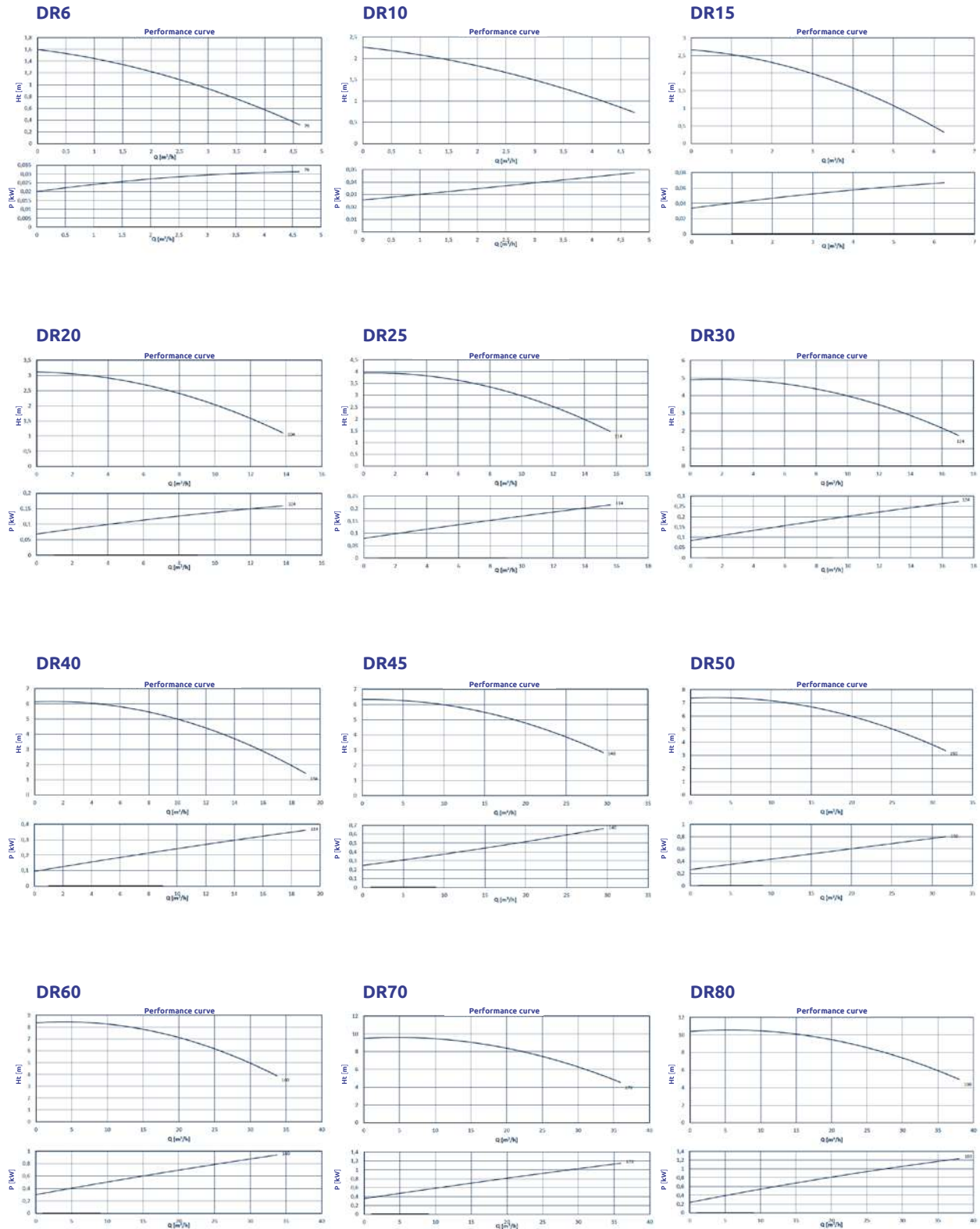

---

# DRAGON ZN HORIZONTAL CENTRIFUGAL PUMPS

Thermoplastic centrifugal pumps with mechanical seal  
for flow rates up to 200 m<sup>3</sup>/h

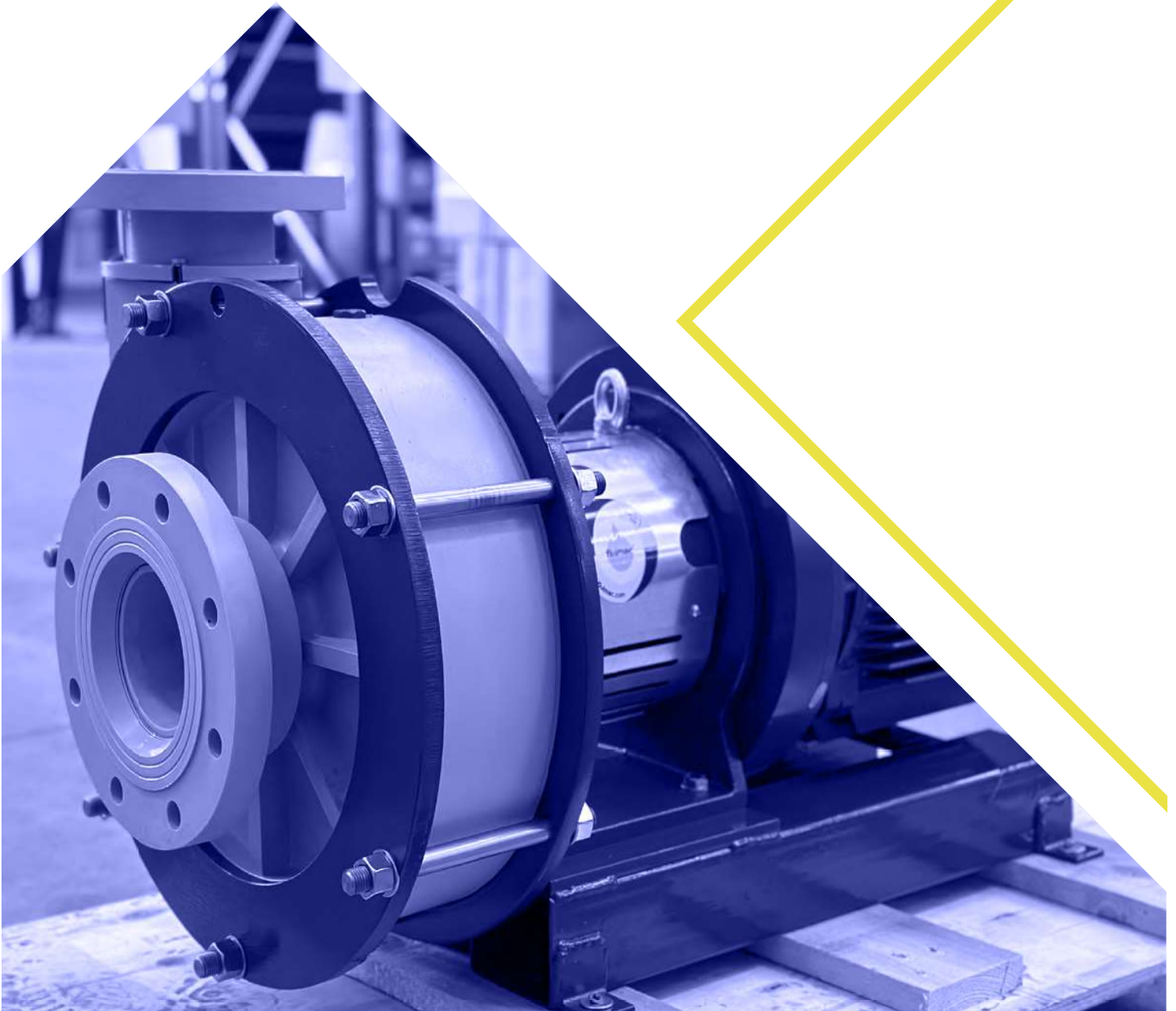

# DRAGON ZN SERIES



The Dragon ZN horizontal centrifugal pump is specifically designed for the safe and efficient transfer of chemically aggressive liquids, even in applications with high flow rates (up to 200 m<sup>3</sup>/h) and high heads. Equipped with IEC type B5 electric motors, this version combines lightweight, compactness, and reliability. The reciprocating design, thanks to a rigid coupling, allows for coupling with standardized IEC electric motors or, upon request, NEMA motors. This version features a single external ceramic/PTFE mechanical seal that operates on the shaft with a PTFE sleeve. The seal is internally flushed according to API PLAN 01. It is also possible to provide an API PLAN 32 type flush with a compatible liquid from an external source that mixes with the pumped fluid to cool and clean the seal chamber and prevent any small deposits.



## TECHNICAL DATA

- Polypropylene, PVDF, glass-filled Moplen®, impellers also available in Ryton®.
- AISI 316L shaft with PTFE or Hastelloy-C sleeve.
- Single or double external mechanical seal in ceramic and PTFE or silicon carbide/silicon carbide.
- No metallic materials come into contact with the pumped liquid.

## PERFORMANCE

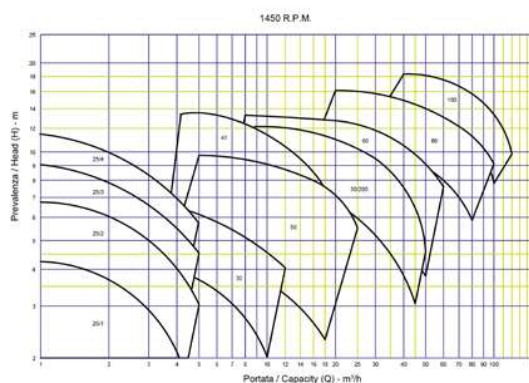

## APPLICATIONS

- Chemical and pharmaceutical production processes
- Galvanic treatments
- Toxic fume abatement systems
- Incinerators
- Fish farming
- Agri-food industries
- Steel industries
- Textile industries
- Sugar refineries
- Paper mills

## PERFORMANCE

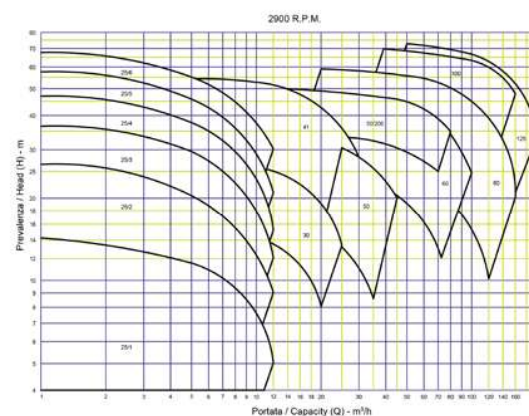

Upon request, the ZN series, for more demanding applications, is also available with a joint and support with two grease-lubricated bearings.

# TYPHOON VERTICAL CENTRIFUGAL PUMPS

Thermoplastic vertical centrifugal pumps



# TYPHOON SERIES



TYPHOON vertical centrifugal pumps are high-efficiency, fixed-installation pumps, with the pump directly immersed in the storage tank. These pumps are used to rapidly empty fluids, with flows ranging from 6 to 80 m<sup>3</sup>/hour. The special design of the semi-open impeller allows continuous pumping even with dirty fluids, with an apparent viscosity of up to 500 cps, and possibly with small, suspended solids. TYPHOON pumps are electrically driven pumps that, through a flexible coupling, transmit rotation to the shaft, and the impeller, thanks to the centrifugal effect, draws in air from the central duct and releases it into the peripheral tube.

## MAIN FEATURES

- Casing and impeller in PP and PVDF
- EPDM and VITON o-ring
- Length from 250mm to 2000mm
- Max. flow rate: 80 m<sup>3</sup>/h; Max. delivery head 45 mts
- Temperature: from -20°C to +95°C
- Max viscosity: 500 CPS
- Electric motors from 0,37 Kw up to 18,5kW
- Specific Gravity up to 1.9

## INSTALLATION



### DRY RUNNING

Suitable devices must be positioned to prevent dry running and the formation of vortices, which could cause subsequent air suction. Dry running or running with air bubbles could damage the pump.

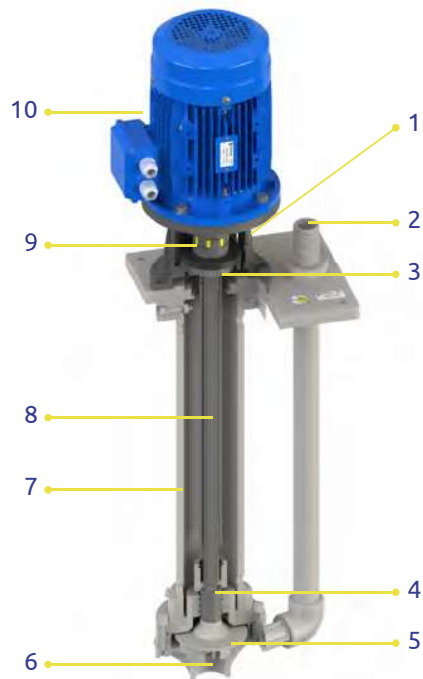

- |          |          |           |                |
|----------|----------|-----------|----------------|
| <b>1</b> | Lantern  | <b>6</b>  | Inlet          |
| <b>2</b> | Outlet   | <b>7</b>  | Column         |
| <b>3</b> | Bearing  | <b>8</b>  | Shaft          |
| <b>4</b> | Bushing  | <b>9</b>  | Coupling       |
| <b>5</b> | Impeller | <b>10</b> | Electric motor |

# TYPHOON SERIES



FLUIMAC coupling is the flexible and homokinetic coupling that assures the best performance in relation to the physical space occupied in its class. It has a very compact design and allows safe power transmission by absorbing peak loads and torsional vibrations. Moreover, the elastic design of the polyurethane gear ring compensates for angular and radial misalignments and also absorbs small shaft length variation.

## MAIN FEATURES

- Compact Design
- Safe power transmission by absorbing peak loads and torsional vibrations
- Compensates for axial misalignments
- Elastic gear ring resistant to Chemical agents

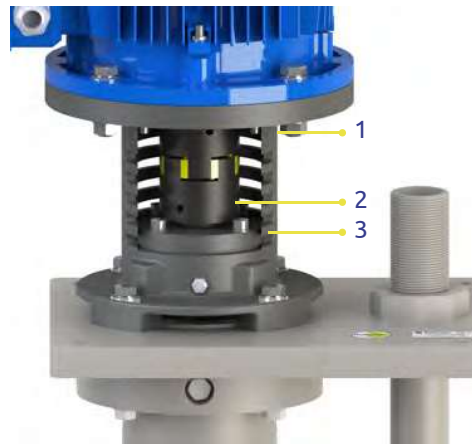

- 1** Lantern
- 2** Flexible coupling
- 3** Radial bearing

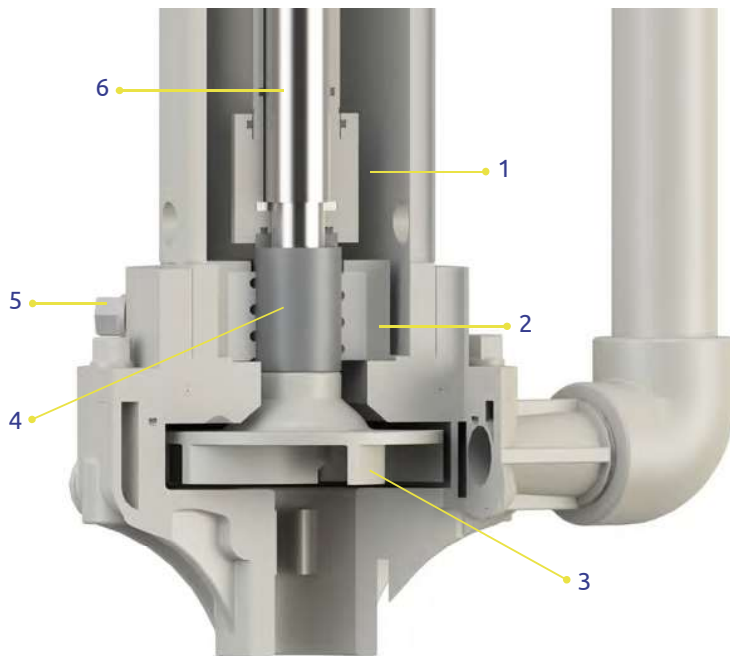

- 1** Shaft guide cover
- 2** PTFE drive bushing
- 3** PP/PVDF impeller
- 4** SiC bushing
- 5** PVDF bolts
- 6** Shaft

# TYPHOON SERIES

# TY 6

PP

PVDF



## TECHNICAL DATA

- Inlet connections 1" 1/2 F BSPP
- Outlet connections 1" M BSPP
- Max. Flow rate 6,2 m<sup>3</sup>/h
- Max. Delivery head 6 m
- Max Viscosity 100 cps
- Temperature PP -5°C +65°C
- Temperature PVDF -20°C +95°C
- Impeller Semi-Opened

## PERFORMANCE

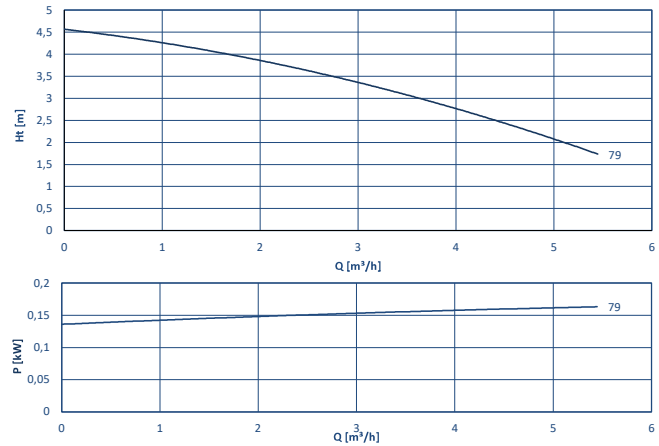

The curves and performance data refer to pumps with free discharge, water at 20°C, and a two-pole, 50 Hz motor. Four-pole curves are available on page 52. This data may vary depending on construction materials and hydraulic conditions.

## MOTOR AND DIMENSIONS

Size	IEC 71	IEC 71	IEC 80
kW	0,37	0,55	0,75
Weight kg*	5,6	6,1	9,1
A* mm	225	225	250
B* mm	183	183	212
C* mm	160	160	200
LT* mm	147	147	147

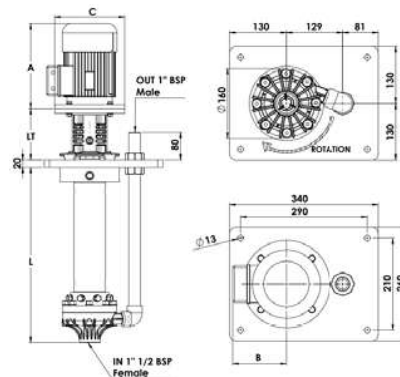

Standard motors: 2 poles, B5, 2900 rpm, 50 Hz, 230/400 V, IP55, IEC flange.

## COMPOSITION

MODEL	CASING	O-RING	LENGTH mm	CONNECTIONS	SIZE	MOTOR
TY006	P = PP	D = EPDM	250	1 = BSPP STD	71	IE = IEC FLANGE
	K = PVDF	V = VITON	500	2 = FLANGED	80	- = NO MOTOR
			800		90	
			1000			

# TYPHOON SERIES

## TY 10

PP

PVDF



### TECHNICAL DATA

- Inlet connections 1" 1/2 F BSPP
- Outlet connections 1" M BSPP
- Max. Flow rate 9,2 m<sup>3</sup>/h
- Max. Delivery head 8,8 m
- Max Viscosity 150 cps
- Temperature PP -5°C +65°C
- Temperature PVDF -20°C +95°C
- Impeller Semi-Opened

### PERFORMANCE

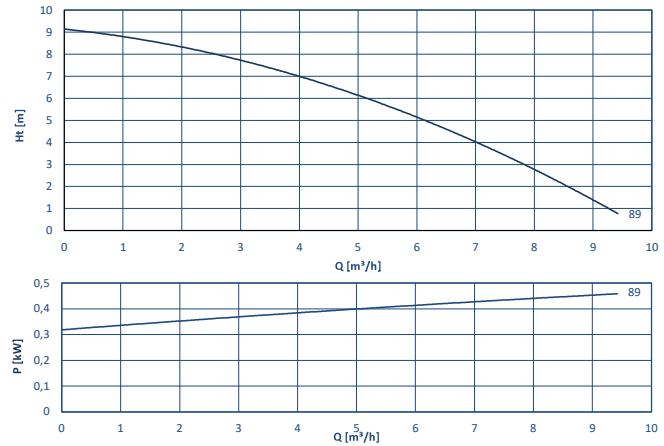

The curves and performance data refer to pumps with free discharge, water at 20°C, and a two-pole, 50 Hz motor. Four-pole curves are available on page 52. This data may vary depending on construction materials and hydraulic conditions.

### MOTOR AND DIMENSIONS

Size	IEC 71	IEC 80	IEC 80	IEC 90S
kW	0,55	0,75	1,1	1,5
Weight kg*	6,1	9,1	10,2	12
A* mm	225	250	250	260
B* mm	183	212	212	230
C* mm	160	200	200	200
LT* mm	147	147	147	157

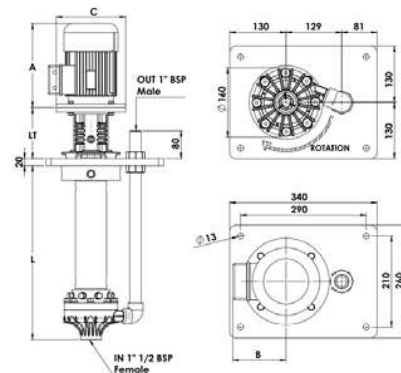

Standard motors: 2 poles, B5, 2900 rpm, 50 Hz, 230/400 V, IP55, IEC flange.

### COMPOSITION

MODEL	CASING	O-RING	LENGTH mm	CONNECTIONS	SIZE	MOTOR
TY010	P = PP	D = EPDM	250	1 = BSPP STD	71	IE = IEC FLANGE
			500	2 = FLANGED	80	
	K = PVDF	V = VITON	800		90	- = NO MOTOR
			1000			

# TYPHOON SERIES

## TY 15

PP

PVDF



### TECHNICAL DATA

- Inlet connections 1" 1/2 F BSPP
- Outlet connections 1" M BSPP
- Max. Flow rate 10,5 m<sup>3</sup>/h
- Max. Delivery head 11,4 m
- Max Viscosity 200 cps
- Temperature PP -5°C +65°C
- Temperature PVDF -20°C +95°C
- Impeller Semi-Opened

### PERFORMANCE

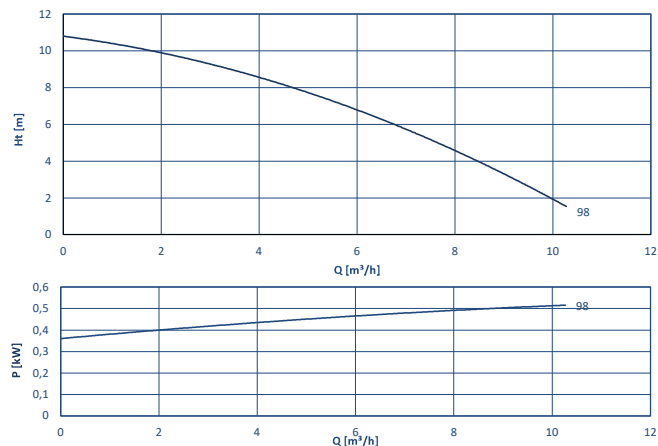

The curves and performance data refer to pumps with free discharge, water at 20°C, and a two-pole, 50 Hz motor. Four-pole curves are available on page 52. This data may vary depending on construction materials and hydraulic conditions.

### MOTOR AND DIMENSIONS

Size	IEC 80	IEC 80	IEC 90S
kW	0,75	1,1	1,5
Weight kg*	9,1	10,2	12
A* mm	250	250	260
B* mm	212	212	230
C* mm	212	212	230
LT* mm	147	147	157

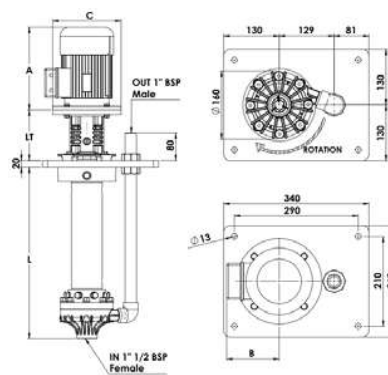

Standard motors: 2 poles, B5, 2900 rpm, 50 Hz, 230/400 V, IP55, IEC flange.

### COMPOSITION

MODEL	CASING	O-RING	LENGTH mm	CONNECTIONS	SIZE	MOTOR
TY015	P = PP	D = EPDM	250	1 = BSPP STD	71	IE = IEC FLANGE
			500	2 = FLANGED	80	
	K = PVDF	V = VITON	800		90	- = NO MOTOR
			1000			

# TYPHOON SERIES

# TY 20

PP

PVDF



## TECHNICAL DATA

- Inlet connections **2" F BSPP**
- Outlet connections **1" 1/2 M BSPP**
- Max. Flow rate **27 m<sup>3</sup>/h**
- Max. Delivery head **15 m**
- Max Viscosity **300 cps**
- Temperature PP **-5°C +65°C**
- Temperature PVDF **-20°C +95°C**
- Impeller **Semi-Opened**

## PERFORMANCE

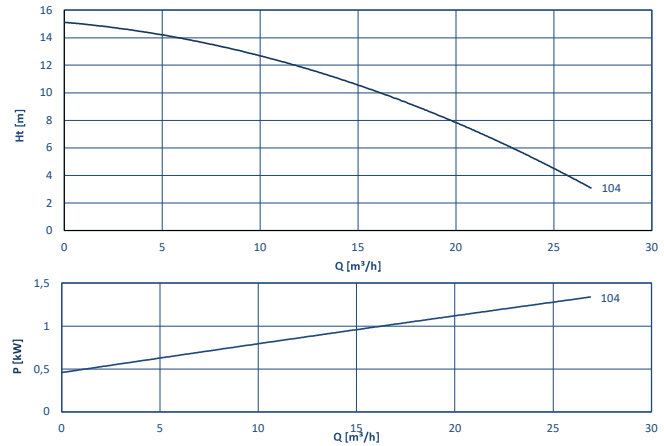

The curves and performance data refer to pumps with free discharge, water at 20°C, and a two-pole, 50 Hz motor. Four-pole curves are available on page 52. This data may vary depending on construction materials and hydraulic conditions.

## MOTOR AND DIMENSIONS

Size	IEC 90S	IEC 90L	IEC 100L	IEC 112	IEC 132S
kW	1,5	2,2	3	4	5,5
Weight kg*	12	15	22,3	26,7	38,5
A* mm	260	285	326	335	356
B* mm	140	140	147	174	187
C* mm	200	200	250	250	300
LT* mm	194	194	194	194	216

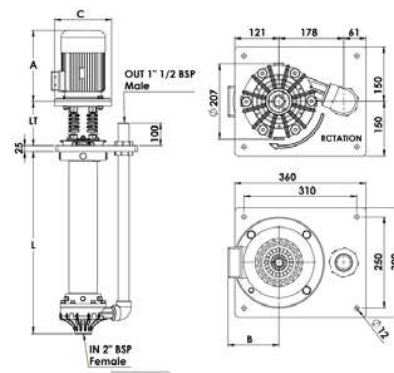

Standard motors: 2 poles, B5, 2900 rpm, 50 Hz, 230/400 V, IP55, IEC flange.

## COMPOSITION

MODEL	CASING	O-RING	LENGTH mm	CONNECTIONS	SIZE	MOTOR
TY020	P = PP	D = EPDM	500	1 = BSPP STD	80	IE = IEC FLANGE
			800		2 = FLANGED	
	K = PVDF	V = VITON	1000			100
			1250		112	
			1500		112	
			1750		112	
			2000		132	

# TYPHOON SERIES

## TY 25

PP

PVDF



### TECHNICAL DATA

- Inlet connections 2" F BSPP
- Outlet connections 1" 1/2 M BSPP
- Max. Flow rate 30 m<sup>3</sup>/h
- Max. Delivery head 18,4 m
- Max Viscosity 400 cps
- Temperature PP -5°C +65°C
- Temperature PVDF -20°C +95°C
- Impeller Semi-Opened

### PERFORMANCE

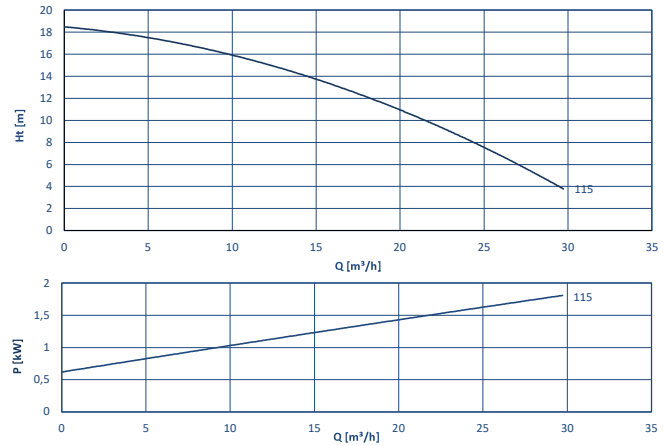

The curves and performance data refer to pumps with free discharge, water at 20°C, and a two-pole, 50 Hz motor. Four-pole curves are available on page 52. This data may vary depending on construction materials and hydraulic conditions.

### MOTOR AND DIMENSIONS

Size	IEC 90S	IEC 90L	IEC 100L	IEC 112	IEC 132S
kW	1,5	2,2	3	4	5,5
Weight kg*	12	15	22,3	26,7	38,5
A* mm	260	285	326	335	356
B* mm	140	140	147	174	187
C* mm	200	200	250	250	300
LT* mm	194	194	194	194	216

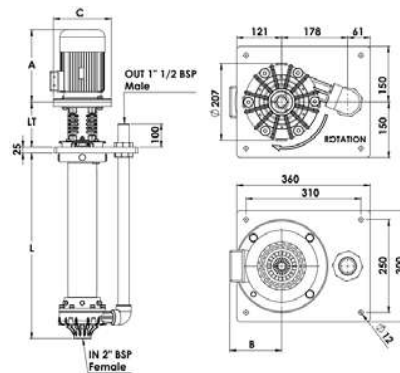

Standard motors: 2 poles, B5, 2900 rpm, 50 Hz, 230/400 V, IP55, IEC flange.

### COMPOSITION

MODEL	CASING	O-RING	LENGTH mm	CONNECTIONS	SIZE	MOTOR	
TY025	P = PP	D = EPDM	500	1 = BSPP STD	80	IE = IEC FLANGE - = NO MOTOR	
			800		2 = FLANGED		90
			1000				100
	1250	112					
	K = PVDF	V = VITON	1500	1750	132		
			1750				
2000							

# TYPHOON SERIES

## TY 30

PP



PVDF



### TECHNICAL DATA

- Inlet connections **2" F BSPP**
- Outlet connections **1" 1/2 M BSPP**
- Max. Flow rate **32 m<sup>3</sup>/h**
- Max. Delivery head **21,7 m**
- Max Viscosity **500 cps**
- Temperature PP **-5°C +65°C**
- Temperature PVDF **-20°C +95°C**
- Impeller **Semi-Opened**

### PERFORMANCE

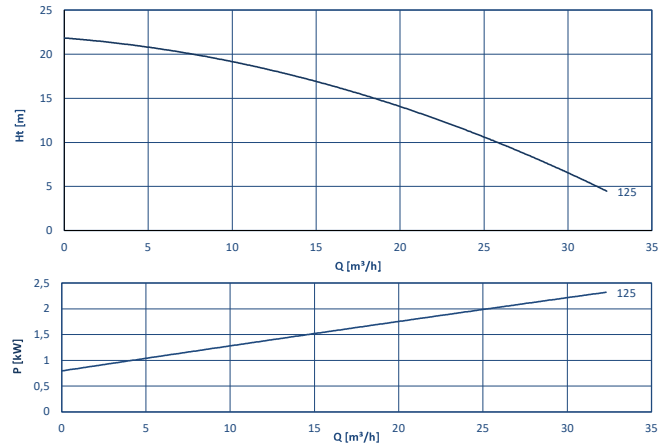

The curves and performance data refer to pumps with free discharge, water at 20°C, and a two-pole, 50 Hz motor. Four-pole curves are available on page 52. This data may vary depending on construction materials and hydraulic conditions.

### MOTOR AND DIMENSIONS

Size	IEC 90L	IEC 100L	IEC 112	IEC 132S
kW	2,2	3	4	5,5
Weight kg*	15	22,3	26,7	38,5
A* mm	285	326	335	356
B* mm	140	147	174	187
C* mm	200	250	250	300
LT* mm	194	194	194	216

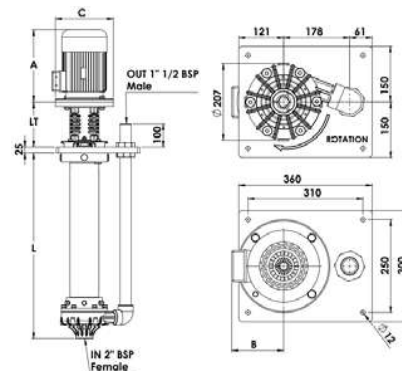

Standard motors: 2 poles, B5, 2900 rpm, 50 Hz, 230/400 V, IP55, IEC flange.

### COMPOSITION

MODEL	CASING	O-RING	LENGTH mm	CONNECTIONS	SIZE	MOTOR
TY030	P = PP	D = EPDM	500	1 = BSPP STD	80	IE = IEC FLANGE
			800		2 = FLANGED	
	K = PVDF	V = VITON	1000			100
			1250		112	
			1500		132	
			1750			
			2000			

# TYPHOON SERIES

## TY 40

PP



PVDF



### TECHNICAL DATA

- Inlet connections **2" F BSPP**
- Outlet connections **1" 1/2 M BSPP**
- Max. Flow rate **35 m<sup>3</sup>/h**
- Max. Delivery head **25 m**
- Max Viscosity **500 cps**
- Temperature PP **-5°C +65°C**
- Temperature PVDF **-20°C +95°C**
- Impeller **Semi-Opened**

### PERFORMANCE

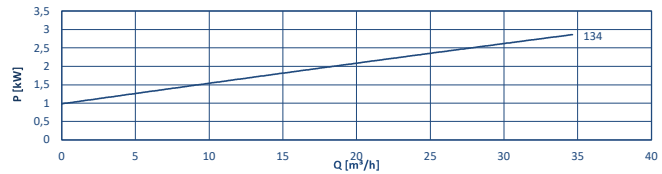
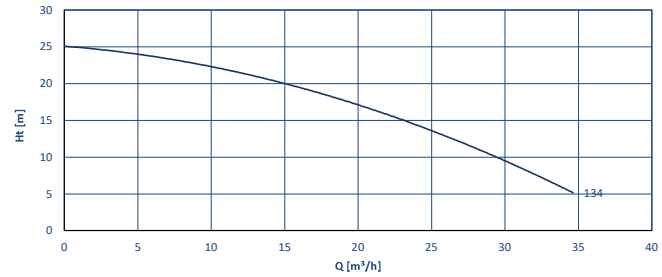

The curves and performance data refer to pumps with free discharge, water at 20°C, and a two-pole, 50 Hz motor. Four-pole curves are available on page 52. This data may vary depending on construction materials and hydraulic conditions.

### MOTOR AND DIMENSIONS

Size	IEC 90L	IEC 100L	IEC 112	IEC 132S	IEC 132S
<b>kW</b>	2,2	3	4	5,5	7,5
<b>Weight kg*</b>	15	22,3	26,7	38,5	42,2
<b>A* mm</b>	285	326	335	356	356
<b>B* mm</b>	140	147	174	187	187
<b>C* mm</b>	200	250	250	300	300
<b>LT* mm</b>	194	194	194	216	216

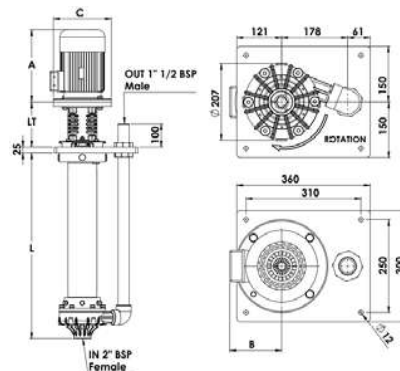

Standard motors: 2 poles, B5, 2900 rpm, 50 Hz, 230/400 V, IP55, IEC flange.

### COMPOSITION

MODEL	CASING	O-RING	LENGTH mm	CONNECTIONS	SIZE	MOTOR
TY040	P = PP	D = EPDM	500	1 = BSPP STD	80	IE = IEC FLANGE
			800		2 = FLANGED	
	K = PVDF	V = VITON	1000			100
			1250		112	
	1500		132			
	1750					
2000						

# TYPHOON SERIES

## TY 45



### TECHNICAL DATA

- Inlet connections 2" 1/2 F BSPP
- Outlet connections 2" M BSPP
- Max. Flow rate 60 m<sup>3</sup>/h
- Max. Delivery head 26 m
- Max Viscosity 500 cps
- Temperature PP -5°C +65°C
- Temperature PVDF -20°C +95°C
- Impeller Semi-Opened

### PERFORMANCE

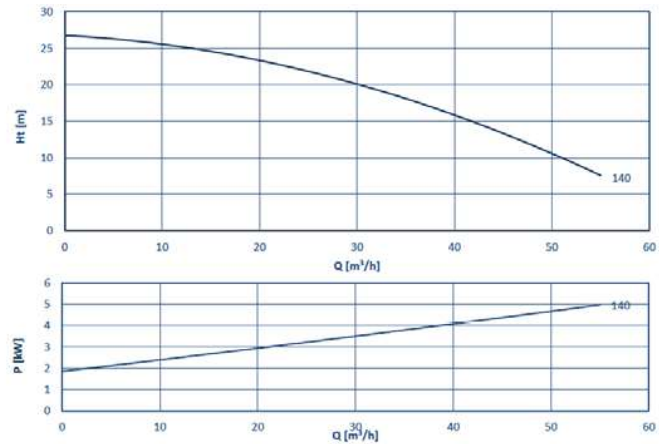

The curves and performance data refer to pumps with free discharge, water at 20°C, and a two-pole, 50 Hz motor. Four-pole curves are available on page 52. This data may vary depending on construction materials and hydraulic conditions.

### MOTOR AND DIMENSIONS

Size	IEC 112	IEC 132S	IEC 132S	IEC 160M
kW	4	5,5	7,5	11
Weight kg*	26,7	38,5	42,2	101
A* mm	335	356	356	500
B* mm	174	187	187	265
C* mm	250	300	300	350
LT* mm	315	315	315	315

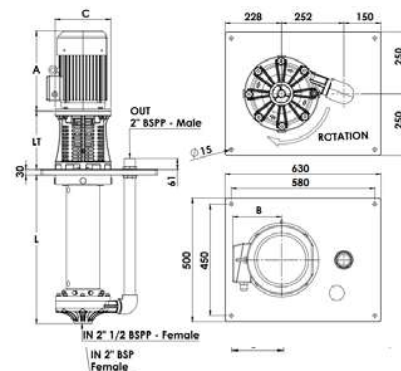

Standard motors: 2 poles, B5, 2900 rpm, 50 Hz, 230/400 V, IP55, IEC flange.

### COMPOSITION

MODEL	CASING	O-RING	LENGTH mm	CONNECTIONS	SIZE	MOTOR
TY045	P = PP	D = EPDM	800	1 = BSPP STD	100	IE = IEC FLANGE
			1000		2 = FLANGED	
	K = PVDF	V = VITON	1250			132
			1500		160	
			1750			
		2000				

# TYPHOON SERIES

# TY 50



## TECHNICAL DATA

- Inlet connections 2" 1/2 F BSPP
- Outlet connections 2" M BSPP
- Max. Flow rate 64 m<sup>3</sup>/h
- Max. Delivery head 30,5 m
- Max Viscosity 600 CPS
- Temperature PP -5°C +65°C
- Temperature PVDF -20°C +95°C
- Impeller Semi-Opened

## PERFORMANCE

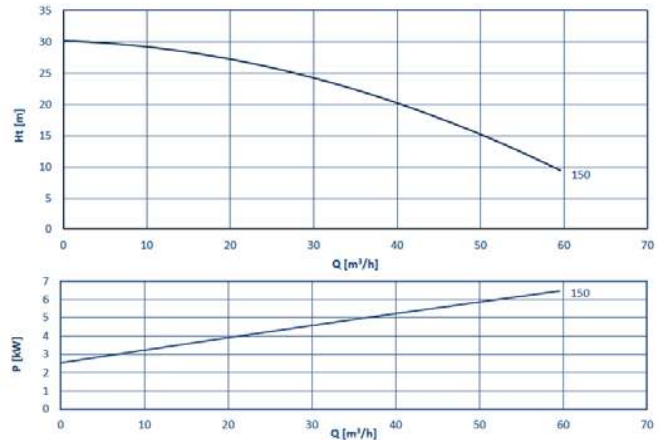

The curves and performance data refer to pumps with free discharge, water at 20°C, and a two-pole, 50 Hz motor. Four-pole curves are available on page 52. This data may vary depending on construction materials and hydraulic conditions.

## MOTOR AND DIMENSIONS

Size	IEC 132S	IEC 132S	IEC 160M	IEC 160M
kW	5,5	7,5	11	15
Weight kg*	38,5	42,2	101	111
A* mm	356	356	500	500
B* mm	1887	1887	265	265
C* mm	300	300	350	350
LT* mm	315	315	315	315

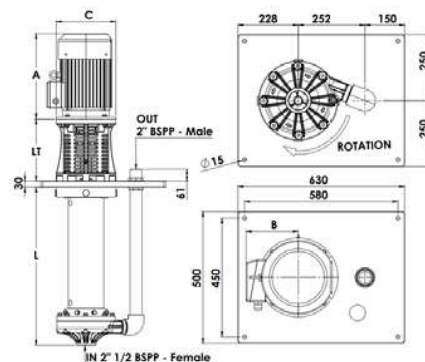

Standard motors: 2 poles, B5, 2900 rpm, 50 Hz, 230/400 V, IP55, IEC flange.

## COMPOSITION

MODEL	CASING	O-RING	LENGTH mm	CONNECTIONS	SIZE	MOTOR
TY050	P = PP	D = EPDM	800	1 = BSPP STD	100	IE = IEC FLANGE
			1000		2 = FLANGED	
	1250	132	- = NO MOTOR			
	1500	160				
	1750					
2000						
	K = PVDF	V = VITON				

# TYPHOON SERIES

## TY 60

PP

PVDF



### TECHNICAL DATA

- Inlet connections 2" 1/2 F BSPP
- Outlet connections 2" M BSPP
- Max. Flow rate **68,5 m<sup>3</sup>/h**
- Max. Delivery head **35 m**
- Max Viscosity **700 CPS**
- Temperature PP **-5°C +65°C**
- Temperature PVDF **-20°C +95°C**
- Impeller **Semi-Opened**

### PERFORMANCE

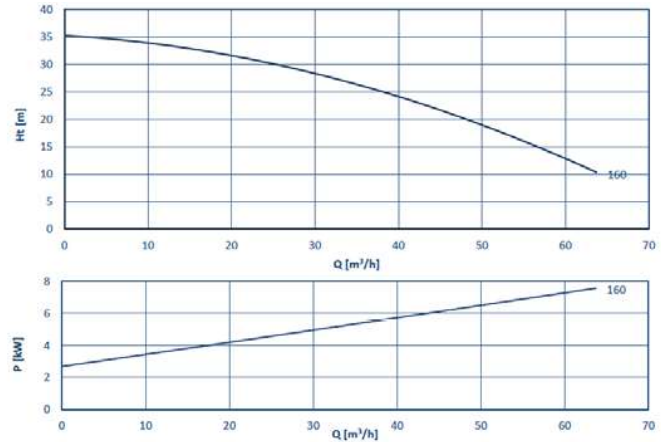

The curves and performance data refer to pumps with free discharge, water at 20°C, and a two-pole, 50 Hz motor. Four-pole curves are available on page 52. This data may vary depending on construction materials and hydraulic conditions.

### MOTOR AND DIMENSIONS

Size	IEC 132S	IEC 132S	IEC 160M	IEC 160M	IEC 160L
kW	5,5	7,5	11	15	18,5
Weight kg*	38,5	42,2	101	111	126
A* mm	356	356	500	500	545
B* mm	187	187	265	265	265
C* mm	300	300	350	350	350
LT* mm	315	315	315	315	315

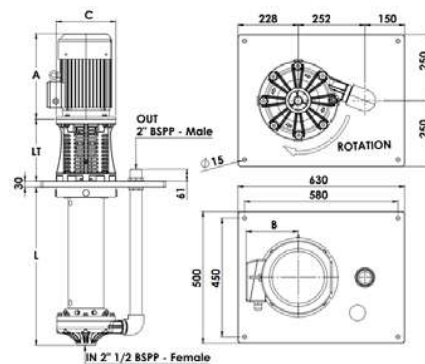

Standard motors: 2 poles, B5, 2900 rpm, 50 Hz, 230/400 V, IP55, IEC flange.

### COMPOSITION

MODEL	CASING	O-RING	LENGTH mm	CONNECTIONS	SIZE	MOTOR
TY060	P = PP	D = EPDM	800	1 = BSPP STD	100	IE = IEC FLANGE
			1000	2 = FLANGED	112	
	1250	132				
	1500	160				
	K = PVDF	V = VITON	1750			- = NO MOTOR
		2000				

# TYPHOON SERIES

## TY 70

PP

PVDF



### TECHNICAL DATA

- Inlet connections 2" 1/2 F BSPP
- Outlet connections 2" M BSPP
- Max. Flow rate 73 m<sup>3</sup>/h
- Max. Delivery head 40 mts
- Max Viscosity 800 CPS
- Temperature PP -5°C +65°C
- Temperature PVDF -20°C +95°C
- Impeller Semi-Opened

### PERFORMANCE

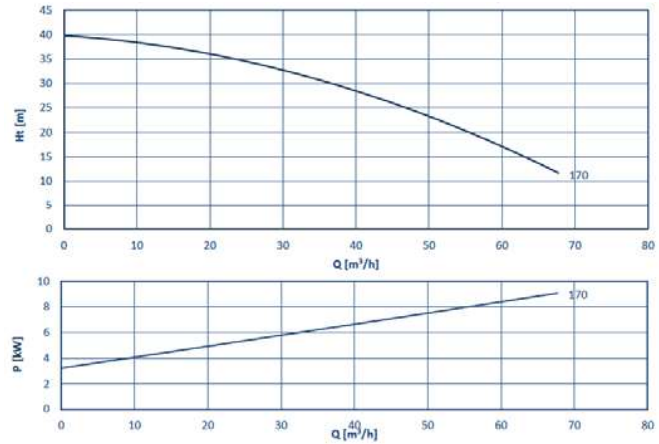

The curves and performance data refer to pumps with free discharge, water at 20°C, and a two-pole, 50 Hz motor. Four-pole curves are available on page 52. This data may vary depending on construction materials and hydraulic conditions.

### MOTOR AND DIMENSIONS

Size	IEC 132S	IEC 160M	IEC 160M	IEC 160L
kW	7,5	11	15	18,5
Weight kg*	42,2	101	111	126
A* mm	356	500	500	545
B* mm	187	265	265	265
C* mm	300	350	350	350
LT* mm	315	315	315	315

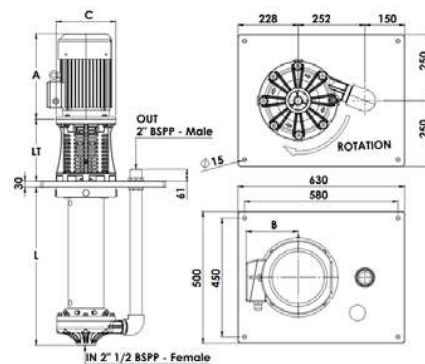

Standard motors: 2 poles, B5, 2900 rpm, 50 Hz, 230/400 V, IP55, IEC flange.

### COMPOSITION

MODEL	CASING	O-RING	LENGTH mm	CONNECTIONS	SIZE	MOTOR
TY070	P = PP	D = EPDM	800	1 = BSPP STD	100	IE = IEC FLANGE
			1000		2 = FLANGED	
	1250	132				
	1500	160				
	1750	160				
	K = PVDF	V = VITON	2000			- = NO MOTOR

# TYPHOON SERIES

## TY 80

PP

PVDF



### TECHNICAL DATA

- Inlet connections 2" 1/2 F BSPP
- Outlet connections 2" M BSPP
- Max. Flow rate 78 m<sup>3</sup>/h
- Max. Delivery head 45 m
- Max Viscosity 800 CPS
- Temperature PP -5°C +65°C
- Temperature PVDF -20°C +95°C
- Impeller Semi-Opened

### PERFORMANCE

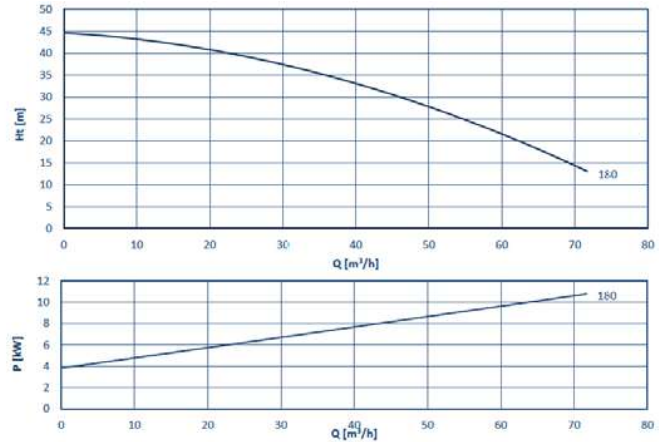

The curves and performance data refer to pumps with free discharge, water at 20°C, and a two-pole, 50 Hz motor. Four-pole curves are available on page 52. This data may vary depending on construction materials and hydraulic conditions.

### MOTOR AND DIMENSIONS

Size	IEC 132S	IEC 160M	IEC 160M	IEC 160L
kW	7,5	11	15	18,5
Weight kg*	42,2	101	111	126
A* mm	356	500	500	545
B* mm	187	265	265	265
C* mm	300	350	350	350
LT* mm	315	315	315	315

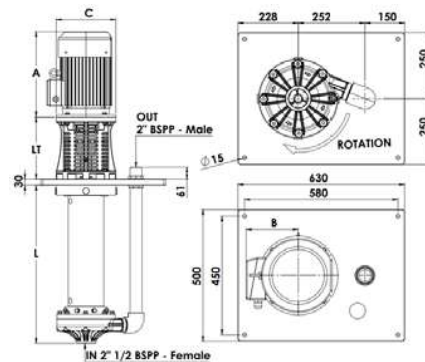

Standard motors: 2 poles, B5, 2900 rpm, 50 Hz, 230/400 V, IP55, IEC flange.

### COMPOSITION

MODEL	CASING	O-RING	LENGTH mm	CONNECTIONS	SIZE	MOTOR
TY080	P = PP	D = EPDM	800	1 = BSPP STD	100	IE = IEC FLANGE
			1000		2 = FLANGED	
	1250	132				
	1500	160				
	K = PVDF	V = VITON	1750			- = NO MOTOR
2000						

# TYPHOON SERIES 4 POLES CURVES

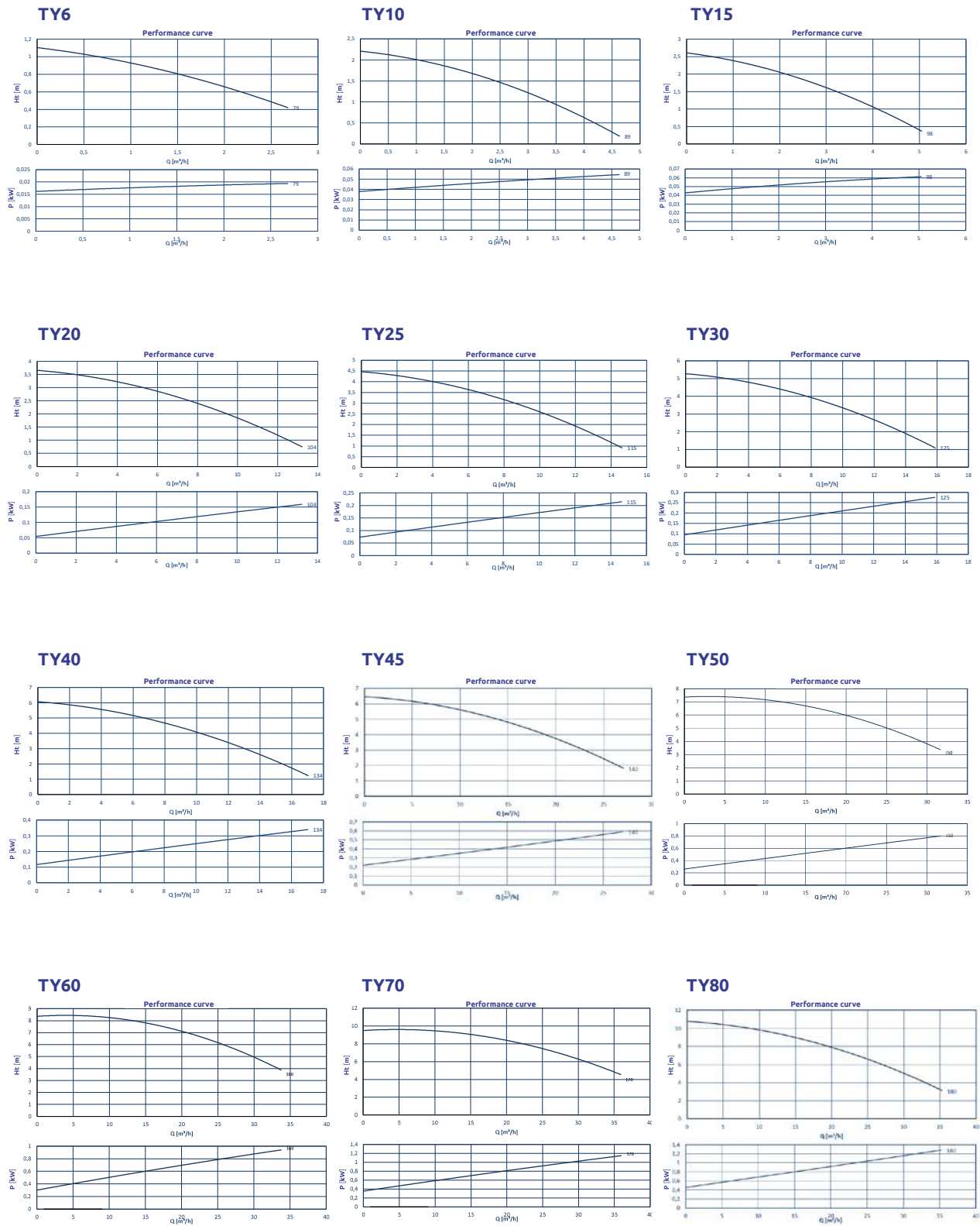

---

# TYPHOON ZPV VERTICAL CENTRIFUGAL PUMPS

Thermoplastic vertical centrifugal pumps for flow rates up to 200 m<sup>3</sup>/h  
and up to 4 meters of column

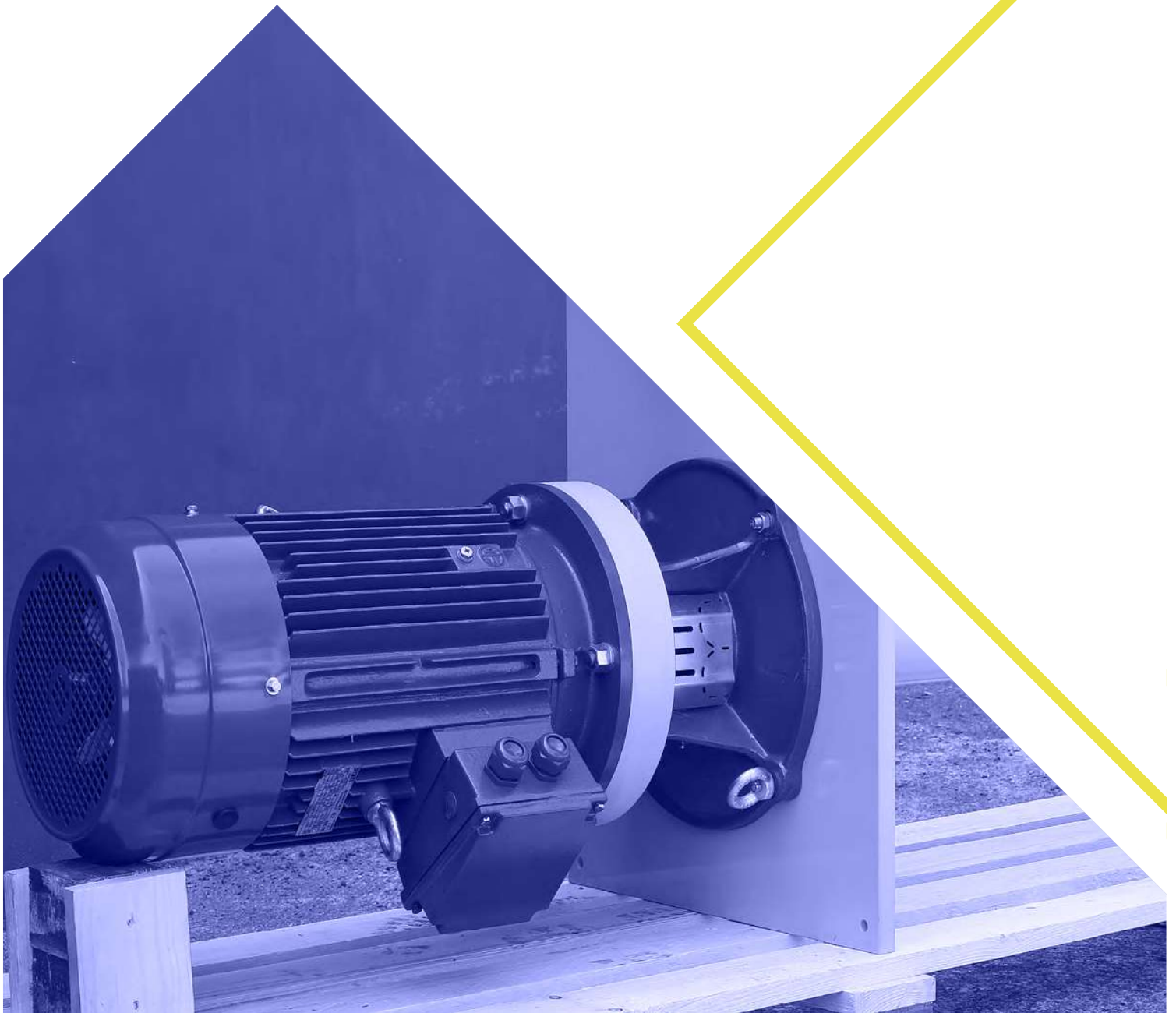

# TYPHOON ZPV SERIES



The Typhoon ZPV vertical centrifugal pump is specifically designed for the safe and efficient transfer of chemically aggressive liquids, even in applications with high flow rates and high heads. Made of a robust polypropylene structure and equipped with IEC form B5 electric motors, the pump guarantees compactness, reliability, and great operational versatility. The motor coupling incorporates a spark-proof elastic coupling and a robust, reinforced, grease-lubricated head bearing. The pump structure can reach a maximum length of 4 meters and is supported by an intermediate bushing made of filled PTFE, lubricated directly by the pumped fluid or via an external circuit with clean liquid.

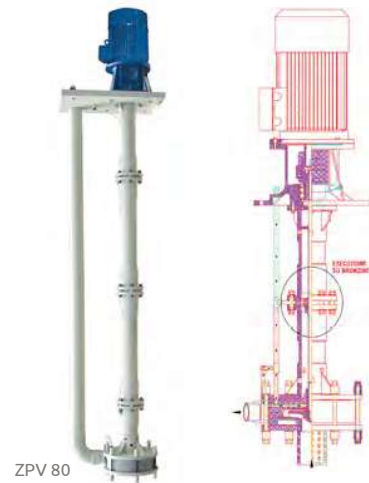

## TECHNICAL DATA

- High-quality materials and components
- Pump body: Polypropylene, PVDF®, fiberglass-reinforced Moplen, or Ryton®
- Shaft: AISI 316 stainless steel covered with polyolefin heat-shrink tubing
- Hastelloy-C® wear sleeves
- Guide sleeves: Filled PTFE
- Seal: Splash flange with Viton® double-lip seal and Hastelloy-C® sleeve

## PERFORMANCE

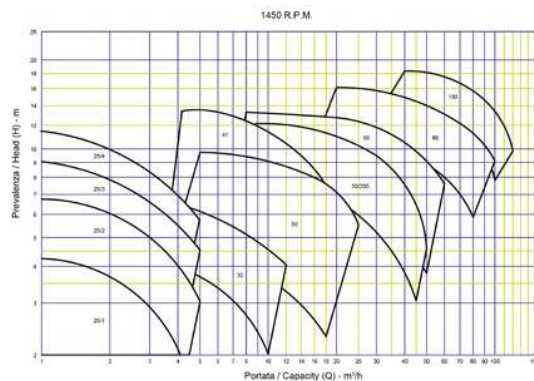

## APPLICATION

- Galvanic plants
- Scrubber systems
- Industrial fume abatement
- Deep tank collection and emptying wells

## PERFORMANCE

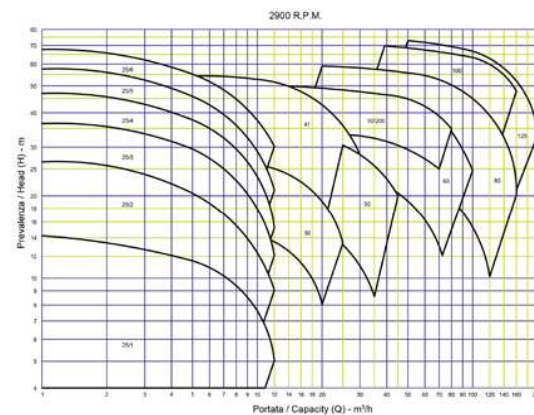

Thanks to the standardization of the shafts and guide tubes, the Typhoon ZPV series pumps ensure short delivery times, high modularity and can be equipped with additional suction tubes to increase the suction depth.

# ACCESSORIES

---

## PP BASKET FILTER FOR HORIZONTAL CENTRIFUGES

Installed on the suction side of the pumps, it protects them from suspended solids and impurities.



## ANTI-VIBRATION FEET KIT

Reduces the normal vibrations of a diaphragm pump.



## DRY RUN PROTECTOR

Connected to the motor, it protects the pump from dry running by detecting Ampere or Cosφ.



## VALVES, FITTINGS AND CONNECTIONS IN PP, PVC, STAINLESS STEEL



## SUCTION FILTERS FOR VERTICAL CENTRIFUGES IN PP AND PVDF



## STAINLESS STEEL TROLLEY

Makes the pump portable.



## STAINLESS STEEL AND PP BASE

Motor support and mounting base.



## BALL FOOT VALVE

Made of PP or PVDF.  
Available sizes:  
1" - 1 1/4" - 1 1/2" - 2".  
Useful to prevent the suction pipe from emptying.



## FLANGE CONNECTION KIT

It modified a pump with BSP connection into a flanged pump.